

AAA TECHNOLOGY

& SPECIALTIES CO., INC.

CONSTANT EFFORT SUPPORTS

TOTAL SOLUTION SERVICE

For the Industrial Piping Marketplace

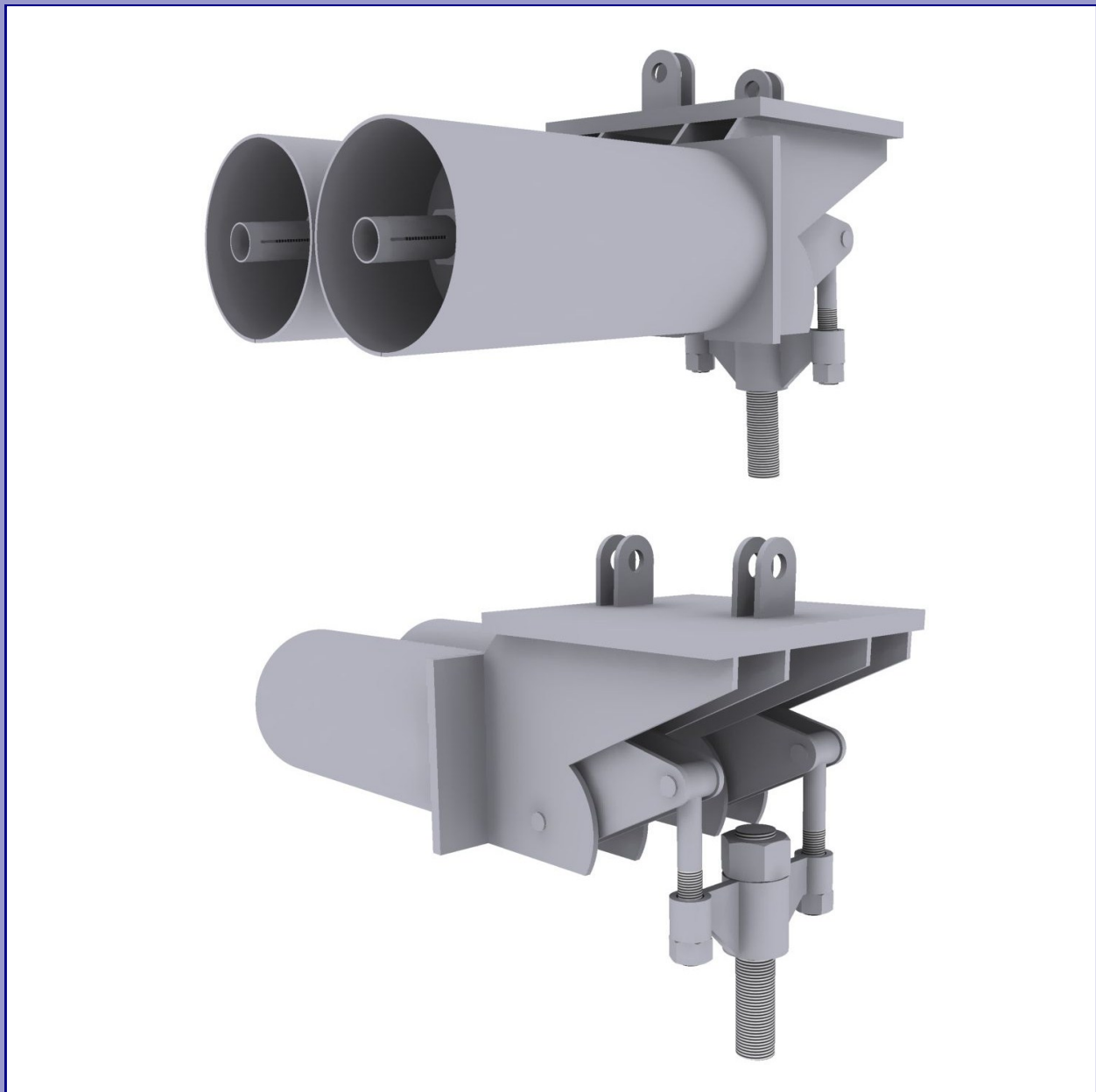



TABLE OF CONTENTS

Introduction & Specifications	2
Application Examples	6-7
Hanger Selection Tables	8-11
S Type—Single Suspension	12-13
D Type—Double Suspension	14-18
B Type—Horizontal Base	19
V Type—Vertical	20-21
VB Type—Vertical Base	22-23
VBS Type—Vertical Base Stanchion	24-25
U Type—Upthrust	26-27

EQUALBALANCE™ CONSTANT EFFORT SUPPORTS

An EQUALBALANCE™ Hanger is a reliable counter-balance with the counterbalance force imposed by a spring coil. By using varying lever arms and spring coil load variation, an accurate constant supporting force is obtained. EQUALBALANCE™ Hangers provide constant support forces for piping systems which move vertically due to thermal expansion or contraction and where the transfer of support load to adjacent hangers and/or equipment is not acceptable.

These hangers have been thoroughly time-tested as evidenced by years of successful operation in a large number of steam generating stations, oil refineries and chemical plants throughout the world.

EQUALBALANCE™ hangers are available in seven different types and a broad variety of sizes to accommodate a wide range of loads, movements and hanger arrangements.

CONSTRUCTION

All EQUALBALANCE™ Hangers are manufactured in conformance with government regulations and industry codes where applicable. Among these are the American Society of Mechanical Engineers' - Codes for Pressure Piping (ASME B31.1 Code for Power Piping and ASME B31.3 Code for Chemical Plant and Petroleum Refinery Piping), the Manufacturers Standardization Society Standards SP - 58 and SP - 69 and the U.S. Government Federal Specification WWW - H - 171 for pipe hangers and supports.

Materials and workmanship of the High Quality along with conservative designs are used to improve the operating life of the EQUALBALANCE™ Hangers in severe service applications. Spring coils of a conservative design are used to guard against any relaxation while in use. All pivot points including lower load rod pivot, are equipped with lifetime, low-friction bearings mounted in accurately constructed and machined frames and assemblies.

TRAVEL STOPS

Each EQUALBALANCE™ Hanger has built-in upper and lower stops to limit the travel a minimum of 12 1/2% beyond the specified actual travel range. Further, the hanger is pinned at the preset position (initial travel position) for the purpose of facilitating installation at a specified position and making it a rigid hanger for the purposes of hydrostatic testing. Please be aware that the EQUALBALANCE™ Hanger will only function properly when the temporary stop has been removed and the hanger load rod is adjusted properly to enable the unit to operate within the specified range of travel. An movement indicator arrow, attached to the movable pivot arm, indicates the travel position at all times.

HYDROSTATIC TEST LOADS

Each EQUALBALANCE™ Hanger is capable of supporting hydrostatic test loads equal to 1.5 times the largest tabulated load for that hanger size range.

LOAD ADJUSTMENT

Each EQUALBALANCE™ Hanger is supplied with a load adjusting nut which permits up to a 10 percent increase or decrease in load-carrying capacity. However, since each EQUALBALANCE™ Hanger is tested on a hydraulic press in our plant and pre-set to a specified load and tested over the range of movement specified by our customer, it is recommended that no field load adjustment be made until it is determined by stress analysis or load cell that a change is necessary. In the event that changes are made, the balance of loads and pipe stresses may be altered. Please remember that turnbuckle adjustments only change the position of the load arm and do not affect the supporting force of the EQUALBALANCE™ Hanger.

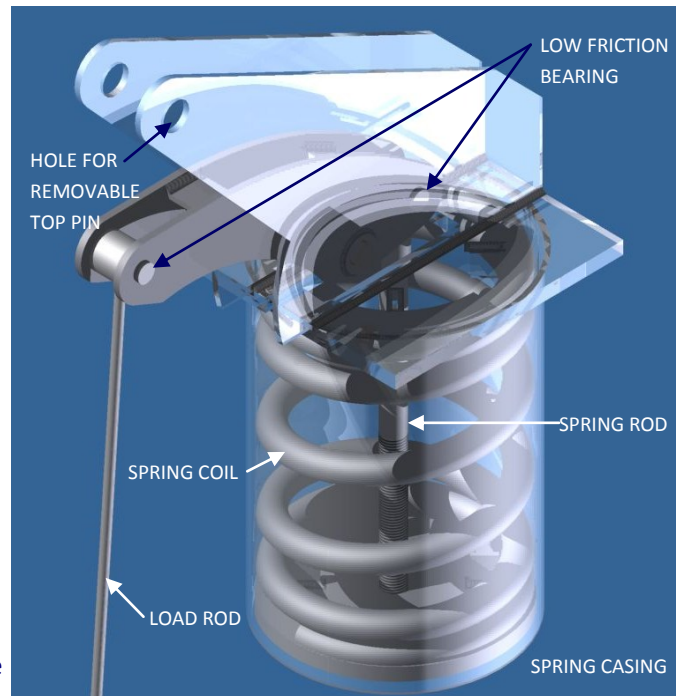



EQUALBALANCE™ CONSTANT EFFORT SUPPORTS

STANDARD HANGERS

The dimensions shown on the following pages are for convenience in selecting the proper type and size EQUALBALANCE™ hangers for your specific requirement. Depending upon the customers' special requirements, the dimensions of the hanger manufactured may be slightly different than the dimensions provided in the catalog. Load to be carried as well as actual travel and direction of travel influence the physical design features of the final hanger. Since the load supporting capacity of all sizes of EQUALBALANCE™ hangers is inversely proportional to the travel magnitude, specifying more travel than necessary will result in a larger and more expensive hanger than actually required.

SPECIAL HANGERS

The drawings and tabulated data on the following pages depict the hanger designs which cover a large percentage of installations. In addition, a number of typical industrial constant spring hanger applications are shown on pages 4 and 5. If constant designs other than those illustrated in this catalog are required, our staff will be pleased to develop custom designs for your review and approval.

In addition to the types and sizes of EQUALBALANCE™ hangers shown in detail in this catalog, the following can also be furnished upon request:

- A. Hangers to handle loads and/or travels beyond the standard ranges shown on pages 8-11.
- B. EQUALBALANCE™ hangers with Neoprene-coated coils and galvanized exposed surfaces can be provided for use in corrosive environments.
- C. Custom top connections.
- D. Extra long lower load rods.
- E. Custom gap turnbuckles.
- F. Nonstandard materials.
- G. Custom load rod connections.

INSTALLATION and SETTING

EQUALBALANCE™ hangers can be installed by an average field worker with little to no difficulty. Placing the hangers in position and adjusting them to carry the desired load at the desired position is easily accomplished. All suspension style EQUALBALANCE™ hangers are designed so that the top connection can be removed in the field and can be bolted or welded separately to the supporting structure or suspended from rods. The hanger frame and casing can then be easily attached by reinserting the removable pin or pins.

All EQUALBALANCE™ hangers have upper and lower stops to limit travel. Hangers with downward travel (pipe moves downward from installed to operating) will be locked (pinned) in the installed position in order to handle the hydrostatic test loading. Hangers with upward travel (pipe moves upward from installed to operating) will be locked (pinned) in the installed position which eliminates the necessity of pulling the hanger to the bottom of the travel when connecting the load rod in the field. All hydrostatic tests should be performed with the constant locked in the installed position. If desired, EQUALBALANCE™ hangers can be supplied locked at any desired point in the total travel range. Just specify the desired locking location when ordering. In all cases, the lock pin can easily be removed by hand by adjusting the turnbuckle on the load carrying rod until the pin is loose. This lock must be removed at the final adjustment or the hanger will not function.

After the hydrostatic test is performed, the final adjustment should consist of turning the turnbuckle so that the hanger is not resting on the travel stop in the installed position. An inspection should be made after the system is in service to insure that the travel indicator is located at the operating position on the travel scale.





EQUALBALANCE™ CONSTANT EFFORT SUPPORTS

When the supported piping system is required to be re-hydrated after start-up, all EQUALBALANCE™ hangers should be re-pinned in the installed position. All hangers should be adjusted, by the turnbuckle, until the pin holes are aligned and the pin can be re-inserted. In a piping system where “cold spring” must be utilized to align a piping system or to pre-stress it, planning ahead is encouraged so that the line can be supported before, during and after the cold spring exercise by adjusting the turnbuckle within its limits. Larger opening turnbuckles are available upon request. EQUALBALANCE™ hangers are supplied with 6” turnbuckles, unless the customer requests a longer opening.

TRAVEL INDICATION

The indicator arrow (mounted on the pivot arm) and travel indicator plate (illustrated below) mounted on the hanger frame indicate the position of travel. The arrow should point to a point on the travel indicator plate under all operating conditions.

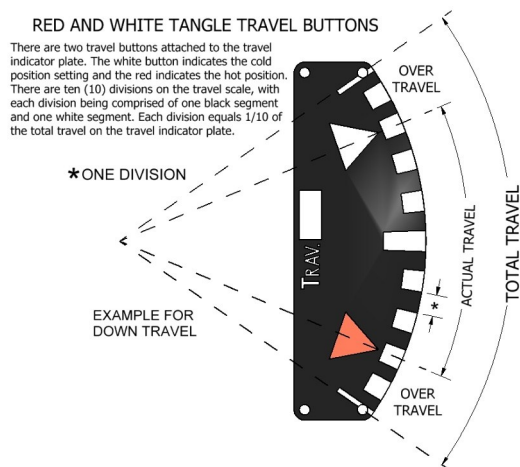

For hangers with downward travel as the pipe moves from installed to operating, the indicator arrow must be near the top of the range when the load rod is properly adjusted for the installed position. For hangers with upward travel as the pipe moves from installed to operating, the indicator arrow must be near the bottom of the range when the load rod is properly adjusted for the installed position.

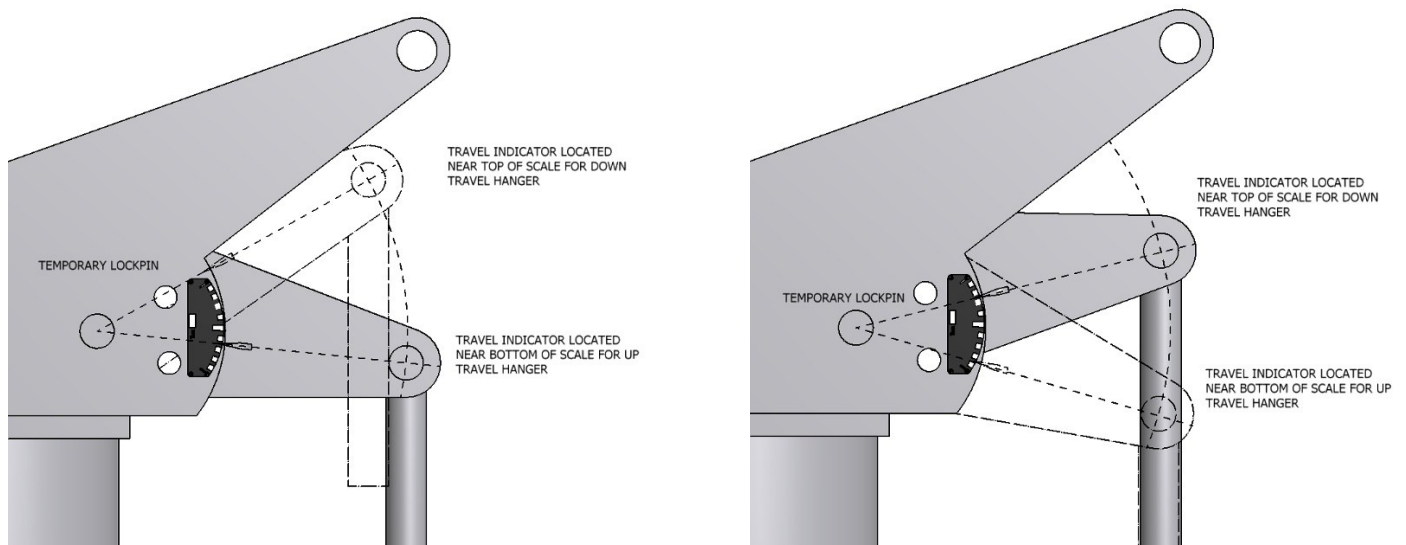



EQUALBALANCE™ CONSTANT EFFORT SUPPORTS

FIELD LOAD ADJUSTMENT

The support load on each EQUALBALANCE™ hanger is set on a hydraulic press and calibrated with a load cell before shipment. Adjustment of the hanger load will modify the load supported by the hanger and may invalidate the design engineer’s stress calculations.

However, in order to provide for cases where the load to be supported is different from the specified load or where a change in hanger location becomes necessary, the EQUALBALANCE™ hanger is provided with a load adjustment mechanism on the tail of the spring rod. Field adjustment can increase or decrease the specified load by as much as 10 percent. As a result, an EQUALBALANCE™ hanger carrying 2,000 lbs can be field adjusted to carry loads from 1,800 to 2,200 lbs.

To adjust the load, loosen the jam nut to which the load sleeve is attached. Turn the main spring rod nut clockwise to increase the load and counter clockwise to decrease the load. When the jam nut is returned to its original position against the main nut, the amount of load adjustment can be read from the position of the indicator on the load scale. When adjustment is completed the jam nut must again be tightened snugly.

The extreme end of the spring rod is equipped with a permanent stop to prevent the complete removal of both the jam nut and sleeve, and the main spring rod nut. Under no circumstances should an attempt be made to remove these nuts from the end of the spring rod.

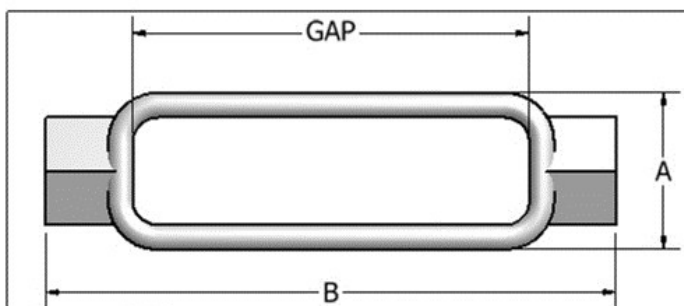
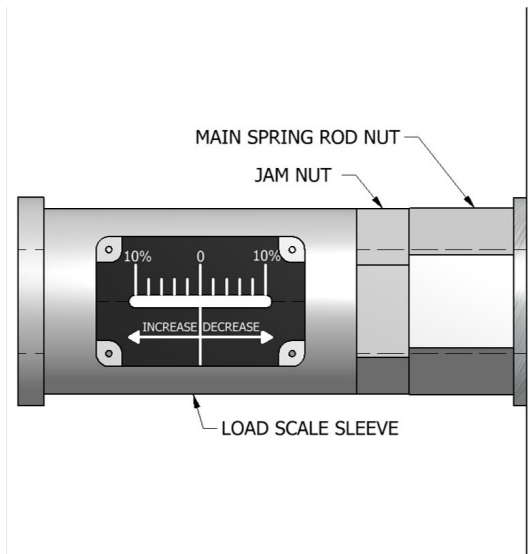

NOTES:

- (1) The allowable loads are based on 9,000 PSI across the root area of the threads @ 650° F, maximum
- (2) Rod diameters through 4 inches are UNC (Coarse) thread series; for 4 1/4 inch diameter thread series is 4 UN.
- (3) Dimension B is given for turnbuckles with a 6 inch GAP. For turnbuckles with a 12 inch gap, add 6" to B" dimension shown.
- (4) Dimensions A and B are approximate and may vary slightly between turnbuckle manufacturers.

ROD AND TURNBUCKLE LOADS AND DIMENSIONS

ROD DIA.	ALLOWABLE LOAD LBS	A	B
3/8"	610	1 1/16"	7 1/8"
1/2"	1130	1 5/16"	7 1/2"
5/8"	1810	1 1/2"	7 7/8"
3/4"	2710	1 3/4"	8 1/4"
1"	4960	2 1/16"	8 3/4"
1 1/4"	8000	2 9/16"	9 1/2"
1 1/2"	11630	3 1/16"	10 1/4"
1 3/4"	15690	3 9/16"	11"
2"	20690	4"	11 3/4"
2 1/4"	27200	4 5/8"	12 3/4"
2 1/2"	33500	5"	13 3/4"
2 3/4"	41600	5 5/8"	14 1/4"
3"	50600	6 1/8"	15"
3 1/4"	60500	6 3/4"	16 1/2"
3 1/2"	71260	6 3/4"	16 1/2"
3 3/4"	82900	8 1/2"	18"
4"	95500	8 1/2"	18"
4 1/4"	108900	9 3/4"	22 1/2"



EQUALBALANCE™ CONSTANT EFFORT SUPPORTS

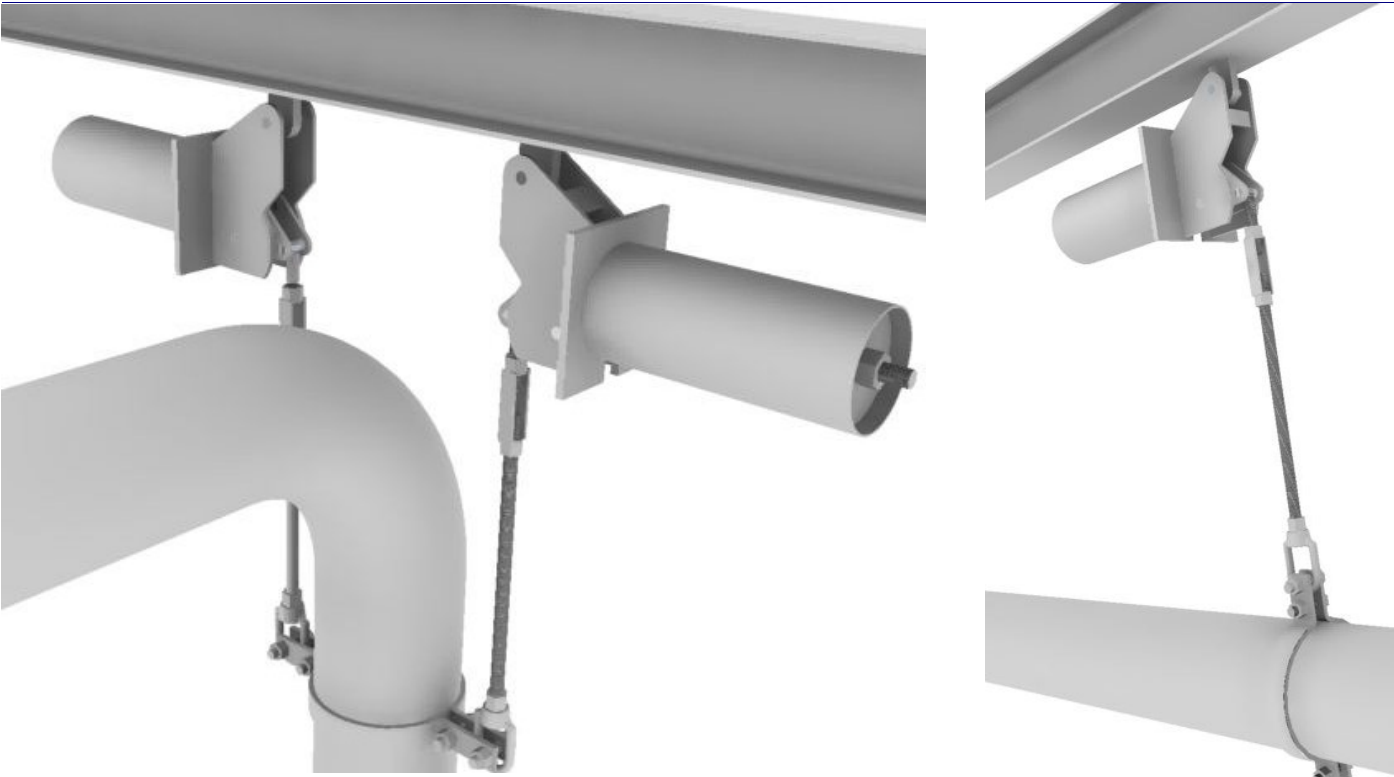

S-TYPE



D-TYPE

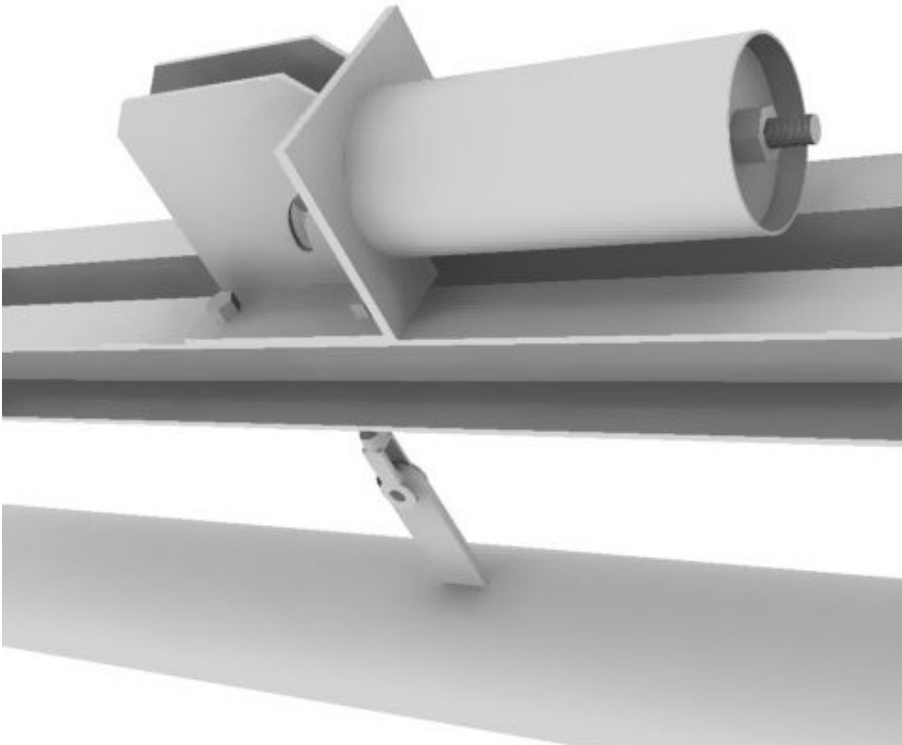

B-TYPE



EQUALBALANCE™ CONSTANT EFFORT SUPPORTS



V-TYPE



VB-TYPE

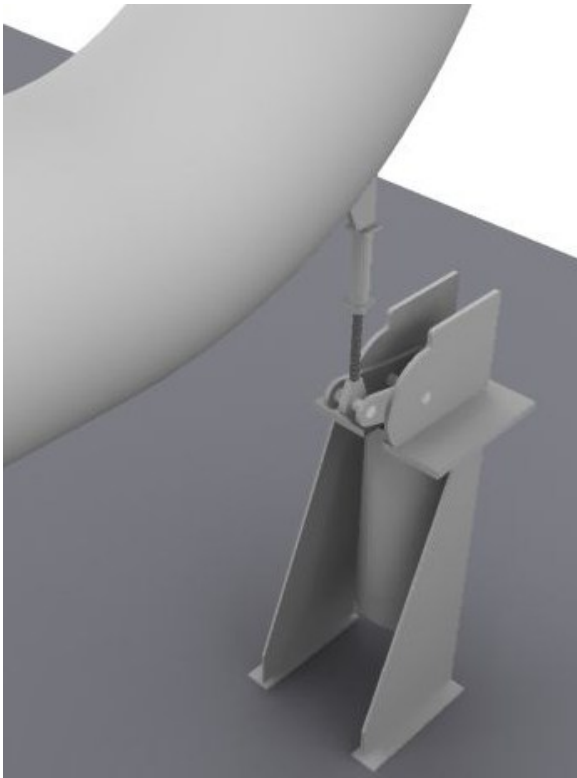

VBS-TYPE

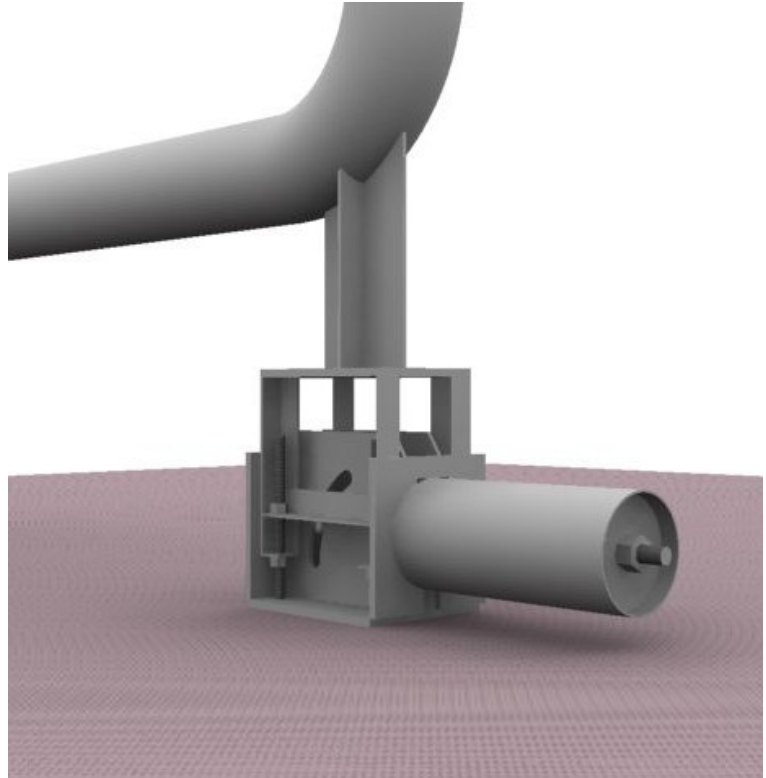

U-TYPE



EQUALBALANCE™ CONSTANT EFFORT SUPPORTS

EQUALBALANCE™ Hanger Selection Table

Hanger Size Selection Instructions: Find the desired total travel on the top data row of the table below. From the desired total travel, move down the load column to the first load equal to or larger than the required load. The correct hanger size will be found in the 'size' column horizontally across to the far left from this load. Although each EQUALBALANCE™ hanger will accommodate a small amount of travel beyond its rated total travel, it is good design to select a hanger that provides a larger travel than expected. In cases where travel cannot be accurately calculated, a more generous total travel should be used to size the hanger.

SIZE	TOTAL TRAVEL (Inches)																		
	1 1/2	2	2 1/2	3	3 1/2	4	4 1/2	5	5 1/2	6	6 1/2	7	7 1/2	8	8 1/2	9	9 1/2	10	10 1/2
1	134	101	80	67	57	50	45	40	37	34	31	29	27	25	24	22	21	20	19
	167	126	100	84	72	63	56	50	46	42	39	36	33	31	30	28	26	25	24
2	207	155	124	103	89	78	69	62	56	52	48	44	41	39	36	34	33	31	30
3	256	192	154	128	110	96	85	77	70	64	59	55	51	48	45	43	40	38	37
4	325	244	195	162	139	122	108	97	89	81	75	70	65	61	57	54	51	49	46
5	403	303	242	202	173	151	134	121	110	101	93	86	81	76	71	67	64	61	58
6	512	384	307	256	219	192	171	154	140	128	118	110	102	96	90	85	81	77	73
7	630	473	378	315	270	236	210	189	172	158	145	135	126	118	111	105	99	95	90
8	787	590	472	393	337	295	262	236	215	197	182	169	157	148	139	131	124	118	112
9	984	738	590	492	422	369	328	295	268	246	227	211	197	185	174	164	155	148	141
10	1230	923	738	615	527	461	410	369	335	308	284	264	246	231	217	205	194	185	176
11	1550	1163	930	775	664	581	517	465	423	388	358	332	310	291	274	258	245	233	221
12	1869	1402	1122	935	801	701	623	561	510	467	431	401	374	351	330	312	295	280	267
13	2003	1503	1202	1002	859	751	668	601	546	501	462	429	401	376	354	334	316	301	286
14	2135	1602	1281	1068	915	801	712	641	582	534	493	458	427	400	377	356	337	320	305
15	2249	1687	1350	1125	964	844	750	675	613	562	519	482	450	422	397	375	355	337	321
16	2361	1771	1417	1181	1012	886	787	708	644	590	545	506	472	443	417	394	373	354	337
17	2657	1993	1594	1329	1139	997	886	797	725	664	613	569	531	498	469	443	420	399	380
18	2952	2214	1771	1476	1265	1107	984	886	805	738	681	633	590	554	521	492	466	443	422
19	3247	2436	1948	1624	1392	1218	1082	974	886	812	749	696	649	609	573	541	513	487	464
20	3543	2657	2126	1771	1518	1329	1181	1063	966	886	818	759	709	664	625	590	559	531	506
21	3936	2952	2362	1968	1687	1476	1312	1181	1073	984	908	843	787	738	695	656	621	590	562
22	4329	3247	2598	2165	1855	1624	1443	1299	1181	1082	999	928	866	812	764	722	684	649	618
23	4723	3543	2834	2362	2024	1771	1574	1417	1288	1181	1090	1012	945	886	834	787	746	709	675
24	5117	3838	3070	2558	2193	1919	1706	1535	1395	1279	1181	1096	1023	959	903	853	808	768	731
25		4244	3395	2829	2425	2122	1886	1698	1543	1415	1306	1213	1132	1061	999	943	893	849	808
26		4650	3720	3100	2657	2325	2066	1860	1691	1550	1431	1328	1240	1162	1094	1033	979	930	886
27		5240	4192	3493	2994	2620	2329	2096	1905	1747	1612	1497	1397	1310	1233	1164	1103	1048	998
28		5830	4664	3887	3331	2915	2591	2332	2120	1943	1794	1666	1555	1458	1372	1296	1227	1166	1110
29		6273	5018	4182	3585	3137	2788	2509	2281	2091	1930	1792	1673	1568	1476	1394	1321	1255	1195
30		6716	5373	4477	3838	3358	2985	2686	2442	2239	2066	1919	1791	1679	1580	1492	1414	1343	1279
31			5934	4945	4239	3709	3297	2967	2697	2473	2282	2119	1978	1854	1745	1648	1562	1484	1413
32			6494	5412	4639	4059	3608	3247	2952	2706	2498	2319	2165	2030	1910	1804	1709	1624	1546
33			7085	5904	5061	4428	3936	3543	3221	2952	2725	2530	2362	2214	2084	1968	1865	1771	1687
34			7675	6396	5482	4797	4264	3838	3489	3198	2952	2741	2558	2399	2257	2132	2020	1919	1827
35			8298	6915	5927	5186	4610	4149	3772	3458	3192	2964	2766	2593	2441	2305	2184	2075	1976
36			8922	7435	6373	5576	4956	4461	4055	3717	3431	3186	2974	2788	2624	2478	2348	2230	2124
37			9604	8003	6860	6003	5336	4802	4365	4002	3694	3430	3201	3001	2825	2668	2527	2401	2287
38			10286	8572	7347	6429	5714	5143	4675	4286	3956	3674	3429	3214	3025	2857	2707	2572	2449
39			11073	9228	7909	6921	6152	5537	5033	4614	4259	3955	3691	3460	3257	3076	2914	2768	2636
40			11860	9884	8472	7413	6589	5930	5391	4942	4562	4236	3953	3706	3488	3295	3121	2965	2824



EQUALBALANCE™ CONSTANT EFFORT SUPPORTS

EQUALBALANCE™ Hanger Selection Table

Hanger Size Selection Instructions: Find the desired total travel on the top data row of the table below. From the desired total travel, move down the load column to the first load equal to or larger than the required load. The correct hanger size will be found in the 'size' column horizontally across to the far left from this load. Although each EQUALBALANCE™ hanger will accommodate a small amount of travel beyond its rated total travel, it is good design to select a hanger that provides a larger travel than expected. In cases where travel cannot be accurately calculated, a more generous total travel should be used to size the hanger.

SIZE	TOTAL TRAVEL (Inches)																		
	11	11 1/2	12	12 1/2	13	13 1/2	14	14 1/2	15	15 1/2	16	16 1/2	17	17 1/2	18	18 1/2	19	19 1/2	20
1	18 23	17 22	17 21	16 20	15 19	15 19	14 18	14 17	13 17	13 16	13 16	12 15	12 15	11 14	11 14	11 14	11 13	10 13	10 13
2	28	27	26	25	24	23	22	21	21	20	19	19	18	18	17	17	16	16	16
3	35	33	32	31	30	28	27	26	26	25	24	23	23	22	21	21	20	20	19
4	44	42	41	39	37	36	35	34	32	31	30	30	29	28	27	26	26	25	24
5	55	53	50	48	47	45	43	42	40	39	38	37	36	35	34	33	32	31	30
6	70	67	64	61	59	57	55	53	51	50	48	47	45	44	43	42	40	39	38
7	86	82	79	76	73	70	68	62	63	61	59	57	56	54	53	51	50	48	47
8	107	103	98	94	91	87	84	81	79	76	74	72	69	67	66	64	62	61	59
9	134	128	123	118	114	109	105	102	98	95	92	89	87	84	82	80	78	76	74
10	168	160	154	148	142	137	132	127	123	119	115	112	109	105	103	100	97	95	92
11	211	202	194	186	179	172	166	160	155	150	145	141	137	133	129	126	122	119	116
12	255	244	234	224	216	208	200	193	187	181	175	170	165	160	156	152	148	144	140
13	273	261	250	240	231	223	215	207	200	194	188	182	177	172	167	162	158	154	150
14	291	279	267	256	246	237	229	221	214	207	200	194	188	183	178	173	169	164	160
15	307	293	281	270	260	250	241	233	225	218	211	204	198	193	187	182	178	173	169
16	322	308	295	283	272	262	253	244	236	229	221	215	208	202	197	191	186	182	177
17	362	347	332	319	307	295	285	275	266	257	249	242	234	228	221	215	210	204	199
18	403	385	369	354	341	328	316	305	295	286	277	268	260	253	246	239	233	227	221
19	443	424	406	390	375	361	348	336	325	314	304	295	287	278	271	263	256	250	244
20	483	462	443	425	409	394	380	366	354	343	332	322	313	304	295	287	280	273	266
21	537	513	492	472	454	437	422	407	394	381	369	358	347	337	328	319	311	303	295
22	590	565	541	520	500	481	464	448	433	419	406	394	382	371	361	351	342	333	325
23	644	616	590	567	545	525	506	489	472	457	443	429	417	405	394	383	373	363	354
24	698	667	640	614	590	569	548	529	512	495	480	465	451	439	426	415	404	394	384
25	772	738	707	679	653	629	606	585	566	548	531	514	499	485	472	459	447	435	424
26	845	809	775	744	715	689	664	641	620	600	581	564	547	531	517	503	489	477	465
27	953	911	873	838	806	776	749	723	699	676	655	635	616	599	582	566	552	537	524
28	1060	1014	972	933	897	864	833	804	777	752	729	707	686	666	648	630	614	598	583
29	1141	1091	1046	1004	965	929	896	865	836	809	784	760	738	717	697	678	660	643	627
30	1221	1168	1119	1075	1033	995	959	926	895	867	840	814	790	768	746	726	707	689	672
31	1349	1290	1236	1187	1141	1099	1060	1023	989	957	927	899	873	848	824	802	781	761	742
32	1476	1412	1353	1299	1249	1203	1160	1120	1082	1047	1015	984	955	928	902	878	855	833	812
33	1610	1540	1476	1417	1363	1312	1265	1222	1181	1143	1107	1074	1042	1012	984	957	932	908	886
34	1744	1669	1599	1535	1476	1421	1371	1323	1279	1238	1199	1163	1129	1096	1066	1037	1010	984	959
35	1886	1804	1729	1660	1596	1537	1482	1431	1383	1338	1297	1257	1220	1185	1153	1121	1092	1064	1037
36	2028	1939	1859	1784	1716	1652	1593	1538	1487	1439	1394	1352	1312	1275	1239	1206	1174	1144	1115
37	2183	2088	2001	1921	1847	1779	1715	1656	1601	1549	1501	1455	1412	1372	1334	1298	1264	1231	1201
38	2338	2236	2143	2057	1978	1905	1837	1773	1714	1659	1607	1558	1513	1469	1429	1390	1353	1319	1286
39	2517	2407	2307	2215	2129	2051	1977	1909	1846	1786	1730	1678	1628	1582	1538	1498	1457	1420	1384
40	2696	2578	2471	2372	2281	2196	2118	2045	1977	1913	1853	1797	1744	1694	1647	1603	1561	1521	1483



EQUALBALANCE™ CONSTANT EFFORT SUPPORTS

EQUALBALANCE™ Hanger Selection Table

Hanger Size Selection Instructions: Find the desired total travel on the top data row of the table below. From the desired total travel, move down the load column to the first load equal to or larger than the required load. The correct hanger size will be found in the 'size' column horizontally across to the far left from this load. Although each EQUALBALANCE™ hanger will accommodate a small amount of travel beyond its rated total travel, it is good design to select a hanger that provides a larger travel than expected. In cases where travel cannot be accurately calculated, a more generous total travel should be used to size the hanger.

SIZE	Total Travel (Inches)																	
	11 1/2	12	12 1/2	13	13 1/2	14	14 1/2	15	15 1/2	16	16 1/2	17	17 1/2	18	18 1/2	19	19 1/2	20
41	2772	2657	2551	2453	2362	2277	2199	2126	2057	1993	1932	1875	1822	1771	1723	1678	1635	1594
42	2966	2843	2729	2624	2527	2437	2353	2274	2201	2132	2067	2007	1949	1895	1844	1795	1749	1706
43	3206	3073	2950	2836	2731	2634	2543	2458	2379	2304	2235	2169	2107	2048	1993	1941	1891	1844
44	3423	3280	3149	3028	2916	2811	2714	2624	2539	2460	2385	2315	2249	2187	2128	2072	2018	1968
45	3697	3543	3401	3270	3149	3037	2932	2834	2743	2657	2577	2501	2429	2362	2298	2238	2180	2126
46	3947	3783	3632	3492	3363	3243	3131	3026	2929	2837	2751	2670	2594	2522	2454	2389	2328	2270
47	4233	4056	3894	3744	3606	3477	3357	3245	3140	3042	2950	2863	2781	2704	2631	2562	2496	2434
48	4518	4330	4156	3997	3849	3711	3583	3464	3352	3247	3149	3056	2969	2886	2808	2734	2664	2598
49	4883	4680	4492	4320	4160	4011	3873	3744	3623	3510	3403	3303	3209	3120	3035	2955	2880	2808
50	5248	5029	4828	4642	4471	4311	4162	4023	3894	3772	3658	3550	3449	3353	3262	3176	3095	3018
51	5476	5248	5038	4844	4665	4498	4343	4198	4063	3936	3817	3704	3599	3499	3404	3315	3230	3149
52	5704	5467	5248	5046	4859	4686	4524	4373	4232	4100	3976	3859	3749	3644	3546	3453	3364	3280
53	5972	5723	5494	5283	5087	4905	4736	4578	4431	4292	4162	4040	3924	3815	3712	3615	3522	3434
54	6239	5979	5740	5519	5315	5125	4948	4783	4629	4484	4348	4221	4100	3986	3878	3776	3679	3588
55	6916	6628	6363	6118	5892	5681	5485	5303	5132	4971	4821	4679	4545	4419	4299	4186	4079	3977
56	7487	7175	6888	6623	6378	6150	5938	5740	5555	5381	5218	5065	4920	4783	4654	4532	4415	4305
57	8378	8029	7708	7412	7137	6882	6645	6423	6216	6022	5840	5668	5506	5353	5208	5071	4941	4818
58	9235	8850	8496	8169	7867	7586	7324	7080	6852	6638	6436	6247	6069	5900	5741	5589	5446	5310
59	10107	9686	9298	8941	8610	8302	8016	7749	7499	7264	7044	6837	6642	6457	6283	6117	5961	5812
60	11082	10620	10195	9803	9440	9103	8789	8496	8222	7965	7724	7496	7282	7080	6889	6707	6535	6372
61	12313	11800	11328	10892	10489	10114	9766	9440	9135	8850	8582	8329	8091	7867	7654	7453	7262	7080
62	13339	12783	12272	11800	11363	10957	10579	10227	9897	9588	9297	9024	8766	8522	8292	8074	7867	7670
63	14884	14264	13693	13167	12679	12226	11805	11411	11043	10698	10374	10069	9781	9509	9252	9009	8778	8558
64	16351	15670	15043	14465	13929	13432	12968	12536	12132	11753	11396	11061	10745	10447	10164	9897	9643	9402
65	17889	17144	16458	15825	15239	14694	14188	13715	13272	12858	12468	12101	11756	11429	11120	10827	10550	10286
66	19566	18751	18001	17308	16667	16072	15518	15001	14517	14063	13637	13236	12858	12500	12163	11843	11539	11250
67	22251	21324	20471	19684	18955	18278	17647	17059	16509	15993	15508	15052	14622	14216	13832	13468	13122	12794
68	25033	23990	23030	22144	21324	20562	19853	19192	18573	17992	17447	16934	16450	15993	15561	15151	14763	14394
69	27814	26655	25589	24605	23693	22847	22059	21324	20636	19991	19385	18815	18278	17770	17290	16835	16403	15993
70	30595	29321	28148	27065	26063	25132	24265	23456	22700	21990	21324	20697	20105	19547	19019	18518	18043	17592
71	34304	32875	31560	30346	29222	28178	27206	26300	25451	24656	23909	23206	22543	21916	21324	20763	20230	19725
72	38012	36429	34971	33626	32381	31224	30148	29143	28203	27321	26493	25714	24980	24286	23629	23007	22418	21857
73	42648	40871	39237	37727	36330	35033	33825	32697	31642	30654	29725	28850	28026	27248	26511	25814	25152	24523
74	47284	45314	43501	41828	40279	38840	37501	36251	35081	33985	32955	31986	31072	30209	29393	28619	27885	27188
75	50065	47979	46060	44289	42648	41125	39707	38383	37145	35984	34894	33868	32900	31986	31122	30303	29526	28788
76	55627	53310	51177	49209	47386	45694	44118	42648	41272	39982	38771	37630	36555	35540	34579	33669	32806	31986
77	61191	58641	56295	54130	52125	50264	48530	46913	45399	43981	42648	41394	40211	39094	38037	37036	36087	35185
78	68607	65749	63119	60691	58443	56356	54413	52599	50902	49312	47817	46411	45085	43833	42648	41526	40461	39449
79	76024	72857	69942	67252	64761	62449	60295	58285	56405	54643	52987	51428	49959	48571	47258	46015	44835	43714
80	85296	81742	78472	75454	72659	70065	67648	65394	63284	61306	59449	57700	56052	54495	53022	51626	50303	49045
81	94567	90627	87002	83656	80557	77680	75002	72502	70163	67970	65911	63972	62144	60418	58785	57238	55771	54376



EQUALBALANCE™ CONSTANT EFFORT SUPPORTS

S TYPE

SINGLE SUSPENSION

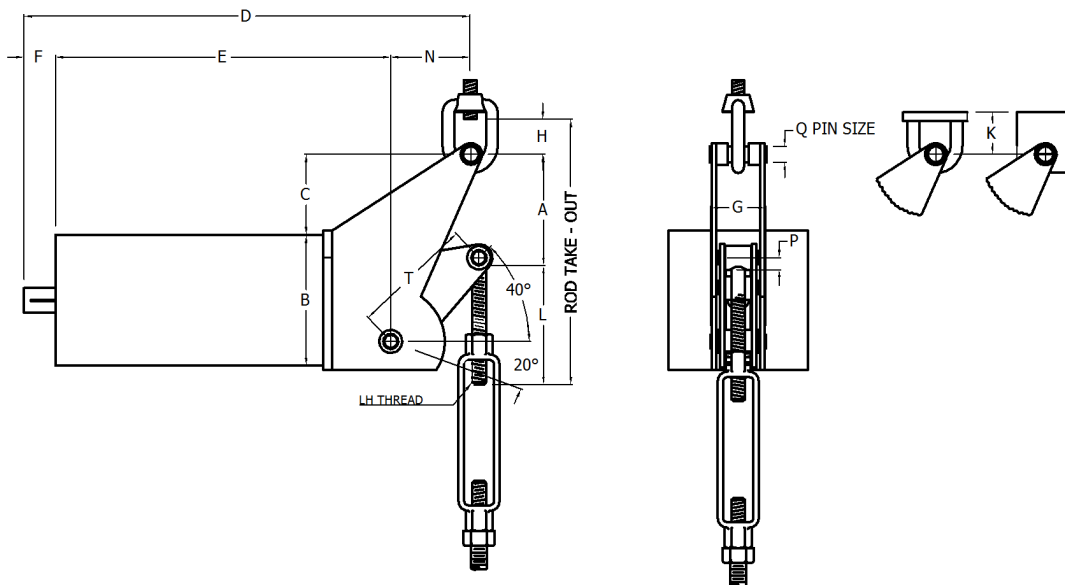
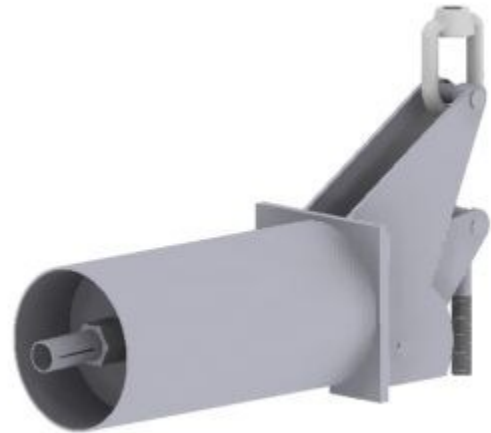

The Type S EQUALBALANCE™ single suspension point hanger is designed for use with a single rod or welding lug top connection. When the S-type EQUALBALANCE™ hanger is suspended by a single rod, the entire hanger can be rotated 360° to avoid interference. When headroom is limited, an alternate top connection, a lug, can be furnished which attaches directly to the building structure. The Type S EQUALBALANCE™ hanger is available for support loads from 19 lbs. through 20,117 lbs. and for total travels from 1 ½ through 20 inches.

SIZE	TOTAL TRAVEL (IN)	STD. ROD DIA. (IN)	B (IN)	E (IN)	F (IN)	G (IN)	K (IN)	P (IN)	Q (IN)	APPROX. UNIT WEIGHT (LBS.)
1 - 9	1 1/2 - 20	1/2 & 5/8	5 9/16	12 3/16	3 11/16	2 7/8	2 5/8	9/16	7/8	35
10 - 24	1 1/2 - 20	1/2 - 1 1/4	9 5/8	15 1/2	4 1/4	4 1/8	3 3/8	7/8	1 1/4	135
25 - 30	2 - 20	5/8 - 1 1/4	11 3/4	16 9/16	4 5/8	4 5/8	3 5/8	1	1 3/8	180
31 - 34	2 1/2 - 20	3/4 - 1 1/4	12 3/4	17 9/16	5 1/16	4 5/8	4 1/8	1 3/16	1 1/2	255
35 - 44	2 1/2 - 20	3/4 - 2	14	24 5/8	6 1/8	6 1/4	5 5/8	1 7/16	2	390
45 - 50	3 - 20	1 - 2 1/4	14	28 7/8	6 1/2	6 1/2	5 5/8	1 9/16	2	530



EQUALBALANCE™ CONSTANT EFFORT SUPPORTS

D TYPE— SIZES 1-66 DOUBLE SUSPENSION

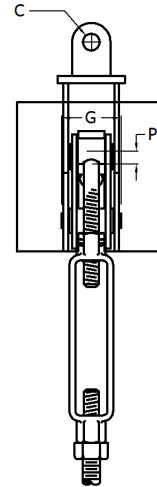
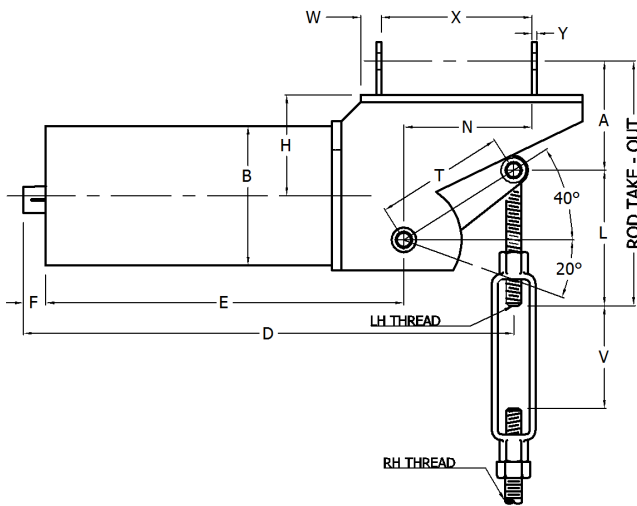

The Type D EQUALBALANCE™ double suspension point hanger is designed to be able to support the heaviest support loads and the longest actual travels. This D-type EQUALBALANCE is furnished with two lugs welded on the top of the frame plate. The lugs can be oriented either along the axis of the hanger casing or perpendicular to the axis of the hanger casing. Mating attachments can be provided with rods and clevises and beam brackets. The Type D EQUALBALANCE™ double suspension point hanger is available for support loads from 19 lbs through 56,252 lbs and for total travels from 1 1/2 through 20 inches.

SIZE	TOTAL TRAV-EL (IN)	STD. ROD DIA. (IN)	B (IN)	C (IN)	E (IN)	F (IN)	G (IN)	H (IN)	N (IN)	P (IN)	W (IN)	X (IN)	Y (IN)	APPROX. UNIT WEIGHT (LBS.)
1 - 9	1 1/2 - 10	1/2 & 5/8	5 9/16	1/2	12 3/16	3 11/16	2 7/8	5	5 3/16	9/16	1	5 1/2	1/2	35
10 - 24	1 1/2 - 3 7/8	5/8 - 1 1/4	8 5/8	3/4	15 1/2	4 1/4	4 1/8	5 1/2	4 5/8	7/8	1 1/2	4 3/4	3/4	145
	4 - 10	5/8 - 3/4		4 7/8					1					
25 - 30	2 - 5 3/8	5/8 - 1 1/4	11 3/4	3/4	16 9/16	4 5/8	4 5/8	7	5 7/16	1	1 1/2	5 3/4	3/4	205
	5 1/2 - 11	5/8 - 3/4		5 11/16					1					
31 - 34	2 1/2 - 7 7/8	3/4 - 1 1/4	12 3/4	3/4	17 9/16	5 1/16	4 5/8	9	8 3/16	1 3/16	1 1/2	8 3/4	3/4	280
	8 - 14	5/8 - 3/4		8 7/16					1					
35 - 44	2 1/2 - 7 7/8	3/4 - 2	14	1 1/4	24 5/8	6 1/8	6 1/4	9 1/4	8 3/4	1 7/16	2 1/4	9	3/4	515
	8 - 14	5/8 - 1		8 3/4					1 1/2					
45 - 50	3 - 9 7/8	1 - 2 1/4	14	1 1/4	28 7/8	6 1/2	6 1/2	10 3/4	9 1/4	1 5/8	2 1/4	10	3/4	655
	10 - 16	3/4 - 1 1/4		9 1/4					1 1/2					
51 - 55	3 - 9 7/8	1 1/4 - 2 1/2	18	1 1/2	30 1/16	7	7	10 3/8	9 1/16	1 5/8	2 3/4	9 1/2	3/4	865
	10 - 16	1 - 1 1/2		9 1/16					1 3/4					
56 - 57	4 - 9 7/8	1 1/2 - 2 1/4	18	1 1/2	32 13/16	7 1/4	8 3/4	11 3/8	9 13/16	2	2 3/4	10 1/2	3/4	1040
	10 - 16	1 1/4 - 1 1/2		9 13/16					1 3/4					
58 - 60	4 - 9 7/8	1 1/2 - 2 1/2	18	1 3/4	34 7/8	7 7/8	8 3/4	11 3/4	11 1/8	2	2 3/4	12	3/4	1310
	10 - 16	1 1/4 - 1 3/4		11 1/8					2 1/4					
61 - 62	4 - 9 7/8	1 3/4 - 2 3/4	18	1 3/4	35 7/8	8 3/8	10	12 3/4	10 7/8	2 1/4	2 3/4	12	3/4	1725
	10 - 18	1 1/2 - 2		10 7/8					2 1/4					
63 - 66	4 - 9 7/8	2 - 3 1/4	22	2	40 15/16	8 3/4	10	13	11 7/16	2 1/4	3 1/2	12	1	2425
	10 - 18	1 1/2 - 2 1/4		11 11/16					2 3/4					



EQUALBALANCE™ CONSTANT EFFORT SUPPORTS

D TYPE SIZES 1-66 (Continued)

DOUBLE SUSPENSION

(For Sizes 1 through 66)

DIMENSION "L"

DIM.	ROD DIAMETER (IN)											
	1/2	5/8	3/4	1	1 1/4	1 1/2	1 3/4	2	2 1/4	2 1/2	2 3/4	3
L	4 3/8	4 5/8	4 7/8	5 1/2	6 1/4	6 3/4	7 1/2	8	8 3/4	9	9 7/8	10 1/2

Dimensions "L" to be increased by 3" for 12" gap turnbuckle.

DIMENSION "A"

SIZE	TOTAL TRAVEL (IN)																				
	1 1/2	2	2 1/2	3	4	5	6	7	8	9	10	11	12	13	14	15	16	17	18	19	20
1 - 9	7 1/8	6 13/16	6 7/16	6 1/8	5 1/2	4 13/16	4 3/16	3 9/16	2 15/16	2 5/16	1 5/8	2	2 3/8	2 11/16	3 1/16	3 7/16	3 3/4	4 1/8	4 1/2	4 7/8	5 1/4
10 - 24	7 15/16	7 5/8	7 1/4	6 15/16	6 5/16	5 5/8	5	4 3/8	3 3/4	3 1/8	2 7/16	2 13/16	3 13/16	3 1/2	3 7/8	4 1/4	4 5/8	4 15/16	5 5/16	5 11/16	6
25 - 30	9 1/4	8 15/16	8 9/16	7 15/16	7 5/16	6 11/16	6	5 3/8	4 3/4	4 1/16	3 7/16	3 13/16	4 1/8	4 1/2	4 7/8	5 1/4	5 9/16	5 15/16	6 5/16	6 5/8	6 5/8
31 - 34		11 1/8	10 3/4	10 1/8	9 1/2	8 13/16	8 3/16	7 9/16	6 15/16	6 1/4	5 5/8	5	4 3/8	3 11/16	4 1/16	4 3/8	4 3/4	5 1/8	5 1/2	5 13/16	5 13/16
35 - 44			12 3/8	12	11 3/8	10 3/4	10 1/16	9 7/16	8 13/16	8 3/16	7 1/2	6 7/8	6 1/4	5 9/16	4 15/16	5 5/16	5 11/16	6	6 3/8	6 3/4	7 1/16
45 - 50				13 11/16	13	12 3/8	11 11/16	11 1/16	10 7/16	9 3/4	9 1/8	8 1/2	7 7/8	7 1/4	6 9/16	5 15/16	5 1/4	5 11/16	6 1/16	6 7/16	6 3/4
51 - 55				14 3/16	13 1/2	12 7/16	12 1/4	11 9/16	10 15/16	10 1/4	9 5/8	9	8 3/8	7 3/4	7 1/16	6 7/16	5 3/4	6 3/16	6 9/16	6 15/16	7 1/4
56 - 57					14 15/16	14 5/16	13 11/16	13	12 3/8	11 3/4	11 1/16	10 7/16	9 13/16	9 3/16	8 1/2	7 7/8	7 1/4	7 9/16	7 15/16	8 5/16	8 5/8
58 - 60					16 3/16	15 9/16	14 15/16	14 1/4	13 5/8	13	12 5/16	11 11/16	11 1/16	10 3/8	9 3/4	9 1/8	8 1/2	8 13/16	9 3/16	9 9/16	9 7/8
61 - 62					17 7/16	16 13/16	16 1/8	15 1/2	14 7/8	14 1/4	13 9/16	12 15/16	12 5/16	11 5/8	11	10 3/8	9 3/4	9 1/16	8 7/16	8 13/16	9 1/8
63 - 66					18 7/16	17 13/16	17 1/8	16 1/2	15 7/8	15 1/4	14 9/16	13 15/16	13 5/16	12 5/8	12	11 3/8	10 3/4	10 1/16	9 7/16	9 13/16	10 1/8

*Dimension "A" is for down travel (cold to hot). For up travel, increase dimension by length of total travel

DIMENSION "D" (MAXIMUM)

SIZE	TOTAL TRAVEL (IN)																				
	1 1/2	2	2 1/2	3	4	5	6	7	8	9	10	11	12	13	14	15	16	17	18	19	20
1 - 9	17 1/16	17 7/16	17 13/16	18 3/16	18 15/16	19 3/4	20 1/2	21 1/4	22	22 3/4	23 9/16	24 5/16	25 1/16	25 13/16	26 5/8	27 3/8	28 1/8	28 7/8	29 11/16	30 7/16	31 3/16
10 - 24	20 15/16	21 5/16	21 11/16	22 1/16	22 13/16	23 9/16	24 3/8	25 1/8	25 7/8	26 5/8	27 7/16	28 3/16	28 15/16	29 11/16	30 1/2	31 1/4	32	32 3/4	33 9/16	34 5/16	35 1/16
25 - 30		22 3/4	23 1/8	23 1/2	24 1/4	25	25 3/4	26 9/16	27 5/16	28 1/8	28 13/16	29 5/8	30 3/8	31 3/16	31 15/16	32 11/16	33 7/16	34 1/4	35	35 3/4	36 1/2
31 - 34			24 9/16	24 15/16	25 11/16	26 1/2	27 1/4	28	28 3/4	29 1/2	30 5/16	31 1/16	31 13/16	32 9/16	33 3/8	34 1/8	34 7/8	35 5/8	36 7/16	37 3/16	37 15/16
35 - 44			32 5/8	33 1/16	33 13/16	34 9/16	35 3/8	36 1/8	36 7/8	37 5/8	38 7/16	39 3/16	39 15/16	40 3/4	41 1/2	42 1/4	43	43 3/4	44 9/16	45 5/16	46 1/16
45 - 50				37 11/16	38 7/16	39 1/4	40	40 3/4	41 1/2	42 1/4	43 1/16	43 13/16	44 9/16	45 3/8	46 1/8	46 7/8	47 5/8	48 3/8	49 3/16	49 15/16	50 11/16
51 - 55				39 5/16	40 1/8	40 15/16	41 11/16	42 7/16	43 3/16	44	44 3/4	45 1/2	46 1/4	47	47 13/16	48 9/16	49 5/16	50 1/16	50 7/8	51 5/8	52 3/8
56 - 57					43 1/8	43 15/16	44 11/16	45 7/16	46 3/16	47	47 3/4	48 1/2	49 1/4	50	50 13/16	51 9/16	52 5/16	53 1/16	53 7/8	54 5/8	55 3/8
58 - 60					45 11/16	46 1/2	47 1/4	48	48 3/4	49 1/2	50 5/16	51 1/16	51 13/16	52 9/16	53 3/8	54 1/8	54 7/8	55 3/4	56 9/16	57 5/16	58 1/16
61 - 62					47 5/16	48 1/16	48 7/8	49 5/8	50 3/8	51 3/16	51 15/16	52 11/16	53 7/16	54 3/16	55	55 3/4	56 1/2	57 1/4	58 1/16	58 13/16	59 9/16
63 - 66					52 3/4	53 1/2	54 1/4	55 1/16	55 13/16	56 9/16	57 5/16	58 1/8	58 7/8	59 5/8	60 7/16	61 3/16	61 15/16	62 11/16	63 1/2	64 1/4	65



EQUALBALANCE™ CONSTANT EFFORT SUPPORTS

D TYPE— SIZES 67-74 DOUBLE SUSPENSION

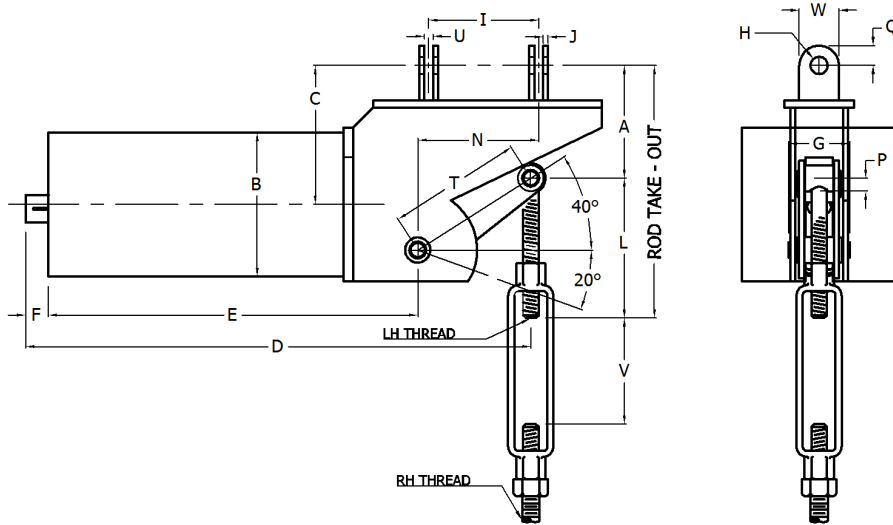

SIZE	TOTAL TRAVEL (IN)	STD. ROD DIA. (IN)	B (IN)	E (IN)	F (IN)	G (IN)	C (IN)	J (IN)	P (IN)	Q (IN)	U (IN)	W (IN)	APPROX. UNIT WT (LBS.)
67	6 - 20	1 3/4 - 3	22	46 1/4	9 1/2	10 7/16	2 1/8	3/4	2 1/4	2 1/2	1 3/4	7	2475
68	6 - 20	1 3/4 - 3	22	47	9 1/2	10 7/16	2 1/8	3/4	2 1/4	2 1/2	1 3/4	7	2500
69	6 - 20	1 3/4 - 3 1/4	22	50	9 1/2	10 7/16	2 1/8	3/4	2 1/4	2 1/2	1 3/4	7	2550
70	6 - 20	2 - 3 1/2	20	51 1/8	9 1/2	10 7/16	2 1/8	3/4	2 1/4	2 1/2	1 3/4	7	2565
71	6 - 20	2 - 3 1/2	20	55 1/8	9 7/8	12 9/16	2 3/8	1	2 1/2	3	2 1/4	8 7/16	3180
72	6 - 20	2 - 3 3/4	18	58 1/4	9 7/8	12 9/16	2 3/8	1	2 1/2	3	2 1/4	8 7/16	3380
73	6 - 20	2 1/4 - 4	18	53 3/8	10 5/8	12 9/16	2 5/8	1	2 5/8	3	2 1/4	8 7/16	3800
74	6 - 20	2 1/4 - 4	24	54 5/8	10 5/8	12 9/16	2 5/8	1	2 5/8	3	2 1/4	8 7/16	4500

DIMENSION "L"

DIM.	ROD DIA. (IN)											
	1 1/4	1 1/2	1 3/4	2	2 1/4	2 1/2	2 3/4	3	3 1/4	3 1/2	3 3/4	4
L	6 1/4	6 3/4	7 1/2	8	8 3/4	9	9 7/8	10 1/2	11 1/2	11 3/4	12 1/2	13 1/4

Dimensions "L" to be increased by 3" for 12" gap turnbuckle.

$$\text{Rod Take-out} = L + A^*$$

DIMENSION "A"

SIZE	TOTAL TRAVEL (IN)															
	6	7	8	9	10	11	12	13	14	15	16	17	18	19	20	
67 - 70	19 3/8	18 3/4	18 1/8	17 1/2	16 13/16	16 3/16	15 9/16	14 7/8	14 1/4	13 5/8	13	12 5/16	11 11/16	11 1/16	10 3/8	
71 - 72	20 5/8	20	19 3/8	18 3/4	18 1/16	17 7/16	16 3/4	16 1/8	15 1/2	14 7/8	14 1/4	13 9/16	12 15/16	12 5/16		
73 - 74	21 3/4	21 1/8	20 1/2	19 13/16	19 3/16	18 9/16	17 15/16	17 1/4	16 5/8	16	15 3/8	14 11/16	14 1/16	13 7/16	12 3/4	

Dimensions "A" is for down travel (cold to hot). For up travel, increase dimension by length of total travel.

DIMENSION "C"

SIZE	TOTAL TRAVEL (IN)					
	6 - 15	16	17	18	19	20
67 - 70	14 3/8	15 3/8	16 3/8	17 3/8	18 3/8	19 3/8
71 - 72	15 3/8	16 3/8	17 3/8	18 3/8	19 3/8	20 3/8
73 - 74	16 3/8	17 3/8	18 3/8	19 3/8	20 3/8	21 3/8

DIMENSION "I" AND "N"

DIM.	TOTAL TRAVEL (IN)					
	6 - 15	16	17	18	19	20
I	14 7/8	15 7/8	16 7/8	17 7/8	18 7/8	19 7/8
N	13 15/16	14 15/16	15 15/16	16 15/16	17 15/16	18 15/16
I	14 7/8	15 7/8	16 7/8	17 7/8	18 7/8	19 7/8
N	14 3/16	15 3/16	16 3/16	17 3/16	18 3/16	19 3/16
I	14 7/8	15 7/8	16 7/8	17 7/8	18 7/8	19 7/8
N	14 13/16	15 13/16	16 13/16	17 13/16	18 13/16	19 13/16



EQUALBALANCE™ CONSTANT EFFORT SUPPORTS

D TYPE—SIZES 67-74 (Continued) DOUBLE SUSPENSION

DIMENSION "D" (MAXIMUM)

SIZE	TOTAL TRAVEL (IN)														
	6	7	8	9	10	11	12	13	14	15	16	17	18	19	20
67	60 3/8	61 1/8	61 7/8	62 5/8	63 7/16	64 3/16	64 15/16	65 11/16	66 1/2	67 1/4	68	68 3/4	69 1/2	70 5/16	71 1/16
68	61 1/8	61 7/8	62 5/8	63 3/8	64 3/16	64 15/16	65 11/16	66 1/2	67 1/4	68	68 3/4	69 1/2	70 5/16	71 1/16	71 13/16
69	64 1/8	64 7/8	65 5/8	66 3/8	67 3/16	67 15/16	68 11/16	69 1/2	70 1/4	71	71 3/4	72 1/2	73 5/16	74 1/16	74 13/16
70	65 1/4	66	66 3/4	67 1/2	68 5/16	69 1/16	69 13/16	70 9/16	71 3/8	72 1/8	72 7/8	73 5/8	74 7/16	75 3/16	75 15/16
71	69 9/16	70 3/8	71 1/8	71 7/8	72 11/16	73 7/16	74 3/16	74 15/16	75 3/4	76 1/2	77 1/4	78	78 3/4	79 9/16	80 1/4
72	72 11/16	73 1/2	74 1/4	75	75 3/4	76 9/16	77 5/16	78 1/16	78 13/16	79 9/16	80 3/8	81 1/8	81 7/8	82 11/16	83 7/16
73	68 9/16	69 3/8	70 1/8	70 7/8	71 5/8	72 7/16	73 3/16	73 15/16	74 11/16	75 1/2	76 1/4	77	77 3/4	78 9/16	79 5/16
74	69 7/8	70 5/8	71 3/8	72 1/8	72 15/16	73 11/16	74 7/16	75 3/16	76	76 3/4	77 1/2	78 1/4	79 1/16	79 13/16	80 9/16

D TYPE—SIZES 75-81 DOUBLE SUSPENSION

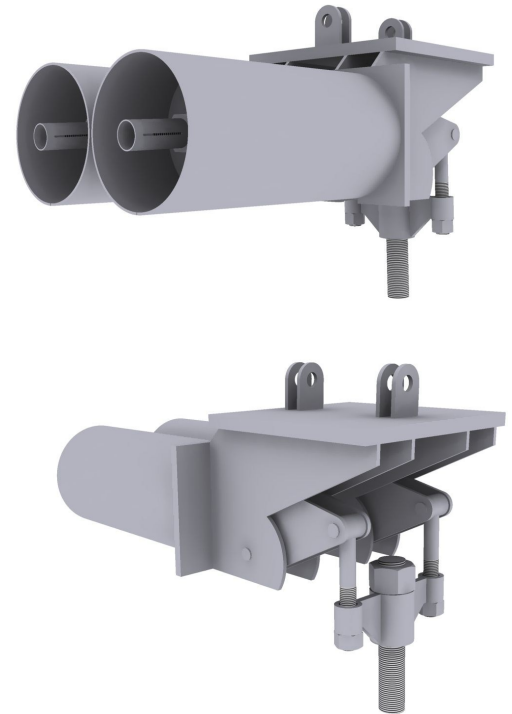
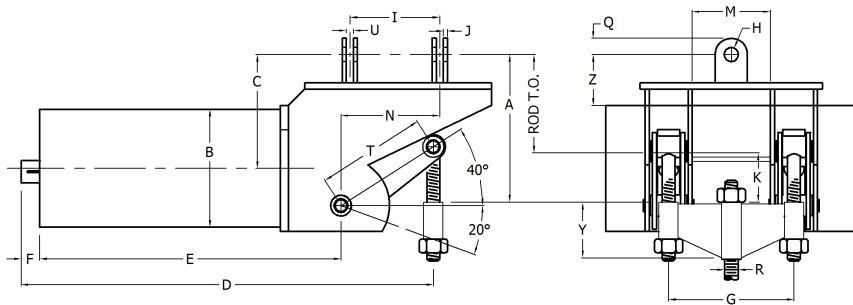

Rod Take-out = A* - K

SIZE	TOTAL TRAVEL (IN)	STD. ROD DIA. (IN)	B (IN)	E (IN)	F (IN)	G (IN)	C (IN)	J (IN)	K (IN)	M (IN)	Q (IN)	U (IN)	Z (IN)	APPROX. UNIT WT (LBS.)
75	7 - 20	2 1/2 - 4	23 15/16	47	9 1/2	27	3 5/8	1 1/4	3 x Rod Dia. (Min.)	18	5	2 3/4	5	5300
76	7 - 20	2 1/2 - 4 1/4	23 15/16	50	9 1/2	27	3 5/8	1 1/4		18	5	2 3/4	5	5700
77	7 1/2 - 20	2 3/4 - 4 1/4	23 15/16	51 1/8	9 1/2	27	3 5/8	1 1/4		18	5	2 3/4	5	5720
78	8 - 20	2 3/4 - 4 1/4	23 15/16	55 1/8	9 7/8	27	3 5/8	1 1/4		16	5	2 3/4	5	5800
79	9 - 20	3 - 4 1/4	23 15/16	58 1/4	9 7/8	27	3 5/8	1 1/4		16	5	2 3/4	5	6400
80	10 - 20	3 1/4 - 4 1/4	23 15/16	53 3/8	10 5/8	27	3 5/8	1 1/4		16	5	2 3/4	5	6670
81	11 - 20	3 1/4 - 4 1/4	26 15/16	54 5/8	10 5/8	30	3 5/8	1 1/2		19	5	2 3/4	5	6950



EQUALBALANCE™ CONSTANT EFFORT SUPPORTS

D TYPE—SIZES 75-81 (Continued)

DOUBLE SUSPENSION

DIMENSION "Y"

ROD DIA.	2 1/2	2 3/4	3	3 1/4	3 1/2	3 3/4	4	4 1/4
75 - 80	8	8	9	9	10	10	11	11
81	8 1/2	8 1/2	9 1/2	9 1/2	11	11	12	12

DIMENSION "C"

SIZE	TOTAL TRAVEL					
	MIN. TO 15	16	17	18	19	20
75 - 77	17 7/8	18 7/8	19 7/8	20 7/8	21 7/8	22 7/8
78 - 79	18 7/8	19 7/8	20 7/8	21 7/8	22 7/8	23 7/8
80 - 81	19 7/8	20 7/8	21 7/8	22 7/8	23 7/8	24 7/8

DIMENSION "I" AND "N"

DIM.	TOTAL TRAVEL					
	MIN. TO 15	16	17	18	19	20
I	14 7/8	15 7/8	16 7/8	17 7/8	18 7/8	19 7/8
N	13 7/8	14 7/8	15 7/8	16 7/8	17 7/8	18 7/8
I	14 7/8	15 7/8	16 7/8	17 7/8	18 7/8	19 7/8
N	13 5/8	14 5/8	15 5/8	16 5/8	17 5/8	18 5/8
I	14 7/8	15 7/8	16 7/8	17 7/8	18 7/8	19 7/8
N	13 5/8	14 5/8	15 5/8	16 5/8	17 5/8	18 5/8

For travels over 15", dimensions "I" & "N" are approximate. These dimensions will vary to match the top connections

DIMENSION "A"

SIZE	TOTAL TRAVEL (IN)													
	7	8	9	10	11	12	13	14	15	16	17	18	19	20
75	31	29 1/4	27 1/4	26 1/2	26	25 1/4	24 3/4	24	21 3/4	22 1/4	22 9/16	22 15/16	23 3/4	24 1/8
76	31	27 3/4	26 3/4	26 1/2	25 1/2	25 1/4	24 3/4	24	21 1/4	22 1/4	22 9/16	22 15/16	23 1/4	23 5/8
77	31	27 3/4	26 3/4	26	25 1/2	24 3/4	24 3/4	24	21 1/4	20 3/4	22 9/16	22 15/16	23 1/4	23 5/8
78		32 1/4	30 3/4	30 1/2	29	28 1/4	28 1/4	27 1/2	25 1/4	24 3/4	25 1/16	25 7/16	25 3/4	26 1/8
79			30 3/4	30	30	28 3/4	27 3/4	27 1/2	25 3/4	24 1/4	25 1/16	25 7/16	25 3/4	26 1/8
80				32	31 1/2	30 1/4	29 3/4	29	27 3/4	27 1/4	27 9/16	26 15/16	27 1/4	27 5/8
81					30 1/2	29 3/4	29 1/4	29	28 1/4	26 3/4	27 9/16	27 15/16	28 1/4	27 5/8

Dimension "A" is for down travel (cold to hot). For up travel, increase dimension by length of total travel.

SIZE	TOTAL TRAVEL (IN)													
	7	8	9	10	11	12	13	14	15	16	17	18	19	20
75	61 7/8	62 5/8	63 3/8	64 3/16	64 15/16	65 11/16	66 7/16	67 1/4	68	68 3/4	69 1/2	70 5/16	71 1/16	71 13/16
76	64 7/8	65 5/8	66 3/8	67 3/16	67 15/16	68 11/16	69 7/16	70 1/4	71	71 3/4	72 1/2	73 5/16	74 1/16	74 13/16
77		66 3/4	67 1/2	68 5/16	69 1/16	69 13/16	70 9/16	71 3/8	72 1/8	72 7/8	73 5/16	74 7/16	75 3/16	75 15/16
78		71 1/8	71 7/8	72 5/8	73 7/16	74 3/16	74 15/16	75 3/4	76 1/2	77 1/4	78	78 13/16	79 9/16	80 5/16
79			75	75 3/4	76 9/16	77 5/16	78 1/16	78 13/16	79 5/8	80 3/8	81 1/8	81 7/8	82 5/8	83 7/16
80				71 5/8	72 7/16	73 3/16	73 15/16	74 3/4	75 1/2	76 1/4	77	77 3/4	78 9/16	79 5/16
81					73 11/16	74 7/16	75 3/16	76	76 3/4	77 1/2	78 1/4	79 1/16	79 13/16	80 9/16



EQUALBALANCE™ CONSTANT EFFORT SUPPORTS

B TYPE HORIZONTAL BASE

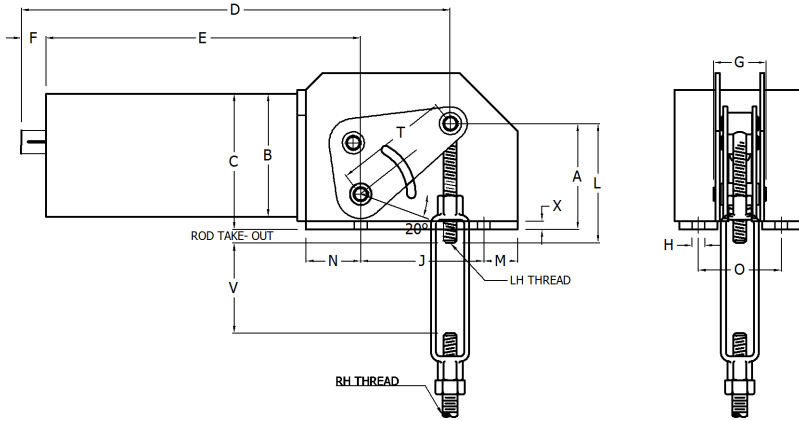
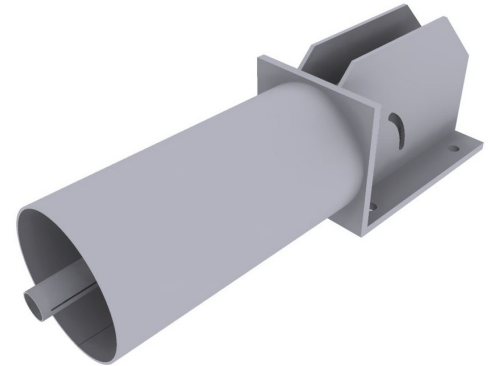

The horizontal base type EQUALBALANCE™ hanger is designed for use in limited headroom applications where available structural support members are above and close to the pipe. The B-type EQUALBALANCE™ may be mounted on top of the supporting steel or inverted beneath the support steel in a trapeze arrangement. The load rod connection is a bushing or a spherical bearing if desired to permit the support rod to swing in both directions. The EQUALBALANCE™ type B hanger is available for support loads from 26 lbs through 90,627 lbs and for total travels

SIZE	TOTAL TRAVEL J (IN)	STD. ROD DIA. (IN)	B (IN)	C (IN)	E (IN)	F (IN)	G (IN)	H (IN)	O (IN)	M (IN)	N (IN)	X (IN)	APPROX. UNIT WEIGHT (LBS.)
1 - 9	1 1/2 - 20	1/2 & 5/8	5 9/16	4 5/8	12 3/16	3 11/16	2 7/8	9/16	4 1/4	2	1 5/16	1/4	40
10 - 24	2 - 20	1/2 - 1	8 5/8	6	15 1/2	4 1/4	4 1/8	9/16	5 3/4	2	1 5/8	3/8	120
25 - 30	3 - 20	5/8 - 1	11 3/4	7 1/2	16 9/16	4 5/8	4 5/8	9/16	6 1/4	2 1/2	1 13/16	3/8	220
31 - 34	3 - 20	5/8 - 1 1/4	12 3/4	8 3/8	17 9/16	5 1/16	4 5/8	13/16	7	2 1/2	2 1/16	3/8	275
35 - 44	4 - 20	5/8 - 1 1/2	14	8 1/2	24 5/8	6 1/8	6 1/4	13/16	8 1/2	3	2 1/2	1/2	475
45 - 50	4 - 20	3/4 - 1 3/4	14	9	28 7/8	6 1/2	6 1/2	13/16	8 3/4	3	3	1/2	540
51 - 55	4 - 20	1 - 2	18	10 5/8	30 1/16	7	7	13/16	9 1/4	4	3 3/16	5/8	825
56 - 57	5 - 20	1 1/4 - 2	18	11 1/2	32 13/16	7 1/4	8 7/8	1 1/16	12 1/2	4	3 7/16	3/4	1165
58 - 60	5 - 20	1 1/4 - 2 1/4	18	11 5/8	34 7/8	7 7/8	8 7/8	1 1/16	12 1/2	4 1/2	3 5/8	3/4	1500
61 - 62	6 - 20	1 1/2 - 2 1/4	18	12 7/8	35 7/8	8 3/8	10	1 1/16	13 1/2	4 1/2	3 7/8	1	1550
63 - 66	6 - 20	1 1/2 - 2 3/4	22	13 3/4	40 15/16	8 3/4	10	1 1/16	13 1/2	5	4 1/16	1	2175
67	6 - 20	2 - 3	22	14	46 1/4	9 1/2	10 1/2	1 1/16	13 1/2	5	4 3/8	1	2475
68	6 - 20	2 - 3 1/4	22	14	47	9 1/2	10 1/2	1 1/16	13 1/2	5	4 3/8	1	2500
69	6 - 20	2 - 3 1/4	22	14	50	9 1/2	10 1/2	1 1/16	13 1/2	5	4 3/8	1	2550
70	6 - 20	2 1/4 - 3 1/2	20	14	51 1/8	9 1/2	10 1/2	1 1/16	13 1/2	5	4 3/8	1	2565
71	6 - 20	2 1/4 - 3 1/2	20	14	55 1/8	9 7/8	12 1/2	1 3/8	16 3/4	6	4 3/4	1 1/4	3180
72	6 - 20	2 1/2 - 3 1/4	18	14	58 1/4	9 7/8	12 1/2	1 3/8	16 3/4	6	4 3/4	1 1/4	3380
73	6 - 20	2 1/2 - 4	18	14	53 3/8	10 5/8	12 9/16	1 3/8	16 3/4	6	5 1/8	1 1/4	3800
74	6 - 20	2 3/4 - 4 1/4	24	15 1/2	54 5/8	10 5/8	12 9/16	1 3/8	16 3/4	6	5 1/8	1 1/4	4500



EQUALBALANCE™ CONSTANT EFFORT SUPPORTS

V TYPE VERTICAL

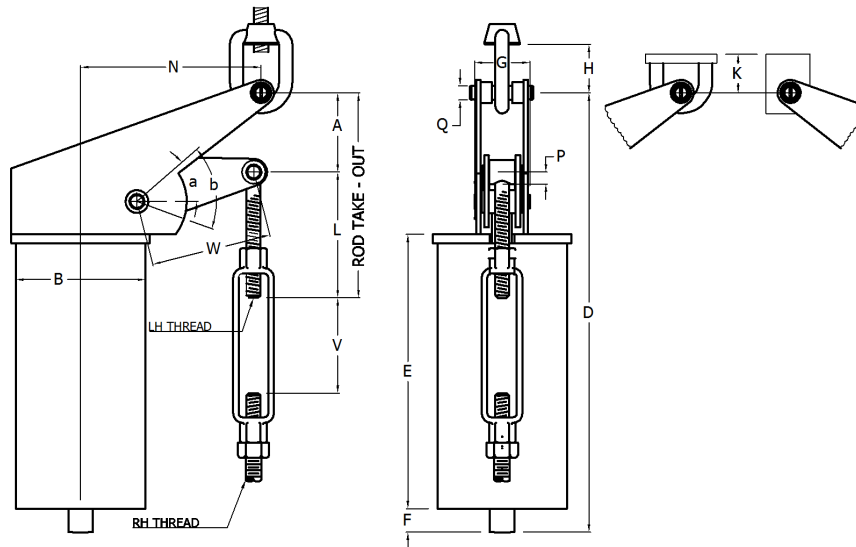

The Type V EQUALBALANCE™ single suspension point hanger is designed for use with a single rod or welding lug top connection and can be used when space limitations restrict the use of a model with a horizontal spring casing. . When the V-type EQUALBALANCE™ hanger is suspended by a single rod, the entire hanger can be rotated 360° to avoid interference. When headroom is limited, an alternate top connection, a lug, can be furnished which attaches directly to the building structure. The Type V EQUALBALANCE™ hanger is available for loads from 10 lbs through 90627 lbs and for travels from 1 ½ through 20 inches.

SIZE	TOTAL TRAVEL (IN)	STD. ROD DIA. (IN)	A* (IN)	B (IN)	E (IN)	F (IN)	G (IN)	K (IN)	P (IN)	Q (IN)	APPROX. UNIT WEIGHT (LBS.)
1 - 9	1 1/2 - 2 3/8	1/2 - 5/8	3 9/16	5 9/16	10 7/8	3 11/16	2 15/16	2 5/8	9/16	7/8	35
	2 1/2 - 20	1/2									
10 - 24	2 - 3 7/8	5/8 - 1	4 1/8	9 5/6	13 7/8	4 1/4	4 3/16	3 3/8	7/8	1 1/4	145
	4 - 20	5/8 - 3/4									
25 - 30	2 - 5 7/8	5/8 - 1 1/4	5	11 3/4	14 3/4	4 5/8	4 5/8	3 5/8	1	1 3/8	180
	6 - 20	5/8 - 3/4									
31 - 34	3 - 6 7/8	5/8 1 1/4	5 11/16	12 3/4	15 1/2	5 1/16	4 5/8	4 1/8	1 3/16	1 1/2	245
	7 - 20	5/8 - 1									
35 - 44	3 - 6 3/8	1 - 1 3/4	6 7/16	14	22 1/8	6 1/8	6 1/4	5 5/8	1 7/16	2	410
	6 1/2 - 20	5/8 - 1 1/4									
45 - 50	4 - 7 7/8	1 1/4 - 1 3/4	7 1/8	14	26	6 1/2	6 1/2	5 5/8	1 9/16	2	615
	8 - 20	1 - 1 1/4									
51 - 55	4 - 8 3/8	1 1/4 - 2	7 9/16	16	26 7/8	7	7	5 1/2	1 9/16	2 1/4	740
	8 1/2 - 20	1 1/4 - 1 1/2									
56 - 57	5 - 9 3/8	1 1/2 - 2	8 1/2	18	29 3/8	7 3/8	8 7/8	5 1/2	2	2 1/4	990
	9 1/2 - 20	1 1/4 - 1 1/2									
58 - 60	5 - 8 7/8	1 3/4 - 2 1/4	9 1/16	18	31 1/4	7 7/8	8 7/8	6 1/8	2	2 1/2	1185
	9 - 20	1 1/4 - 1 3/4									
61 - 62	6 - 10 7/8	1 3/4 - 2 1/4	10 1/4	18	32	8 3/8	10	7 1/4	2 1/4	2 3/4	1600
	11 - 20	1 1/4 - 1 3/4									
63 - 66	6 - 10 7/8	2 - 2 3/4	11 1/4	22	36 7/8	8 3/4	10	7 5/8	2 1/4	3	2400
	11 - 20	1 1/2 - 2 1/4									
67 - 70	6 - 11 7/8	2 1/4 - 3 1/4	12 5/16	22	48 3/4	9 1/2	10 1/2	7 3/4	2 1/4	3 1/2	2540
	12 - 20	2 1/4 - 3 1/4									
71 - 72	6 - 12 7/8	2 1/2 - 3 3/4	13 1/2	20	58 1/2	9 7/8	12 1/2	8 3/8	2 1/2	4	3355
	13 - 20	2 - 2 3/4									
73 - 74	6 - 12 7/8	2 3/4 - 4	14 5/8	18	49 1/2	10 5/8	12 1/2	8 5/8	2 5/8	4 1/4	4475
	13 - 20	2 1/4 - 3									



EQUALBALANCE™ CONSTANT EFFORT SUPPORTS

V TYPE VERTICAL

DIMENSION "H" AND "L"

DIM.	ROD DIA. (IN)															
	1/2	5/8	3/4	1	1 1/4	1 1/2	1 3/4	2	2 1/4	2 1/2	2 3/4	3	3 1/4	3 1/2	3 3/4	4
H	3/4	1 1/8	1 1/4	1 1/2	2	2 1/4	2 3/8	3	3	3	3	3 1/2	N/A	N/A	N/A	N/A
L	4 3/8	4 5/8	4 7/8	5 1/2	6 1/4	6 3/4	7 1/2	8	8 3/4	9	9 7/8	10 1/2	11 1/2	11 3/4	12 1/2	13 1/4

Dimensions "L" to be increased by 3" for 12" gap turnbuckle.

DIMENSION "N"

SIZE	TOTAL TRAVEL (IN)																			
	1 1/2	2	3	4	5	6	7	8	9	10	11	12	13	14	15	16	17	18	19	20
1 - 9	5 9/16	6 1/8	4 13/16	5 9/16	6 5/16	7 1/16	7 7/8	8 5/8	9 3/8	10 3/16	10 15/16	11 11/16	12 7/16	13 1/4	14	14 3/4	15 1/2	16 5/16	17 1/16	17 13/16
10 - 24		6 3/16	7 3/8	5 9/16	6 5/16	7 1/16	7 7/8	8 5/8	9 3/8	10 3/16	10 15/16	11 11/16	12 7/16	13 1/4	14	14 3/4	15 1/2	16 5/16	17 1/16	17 13/16
25 - 30		8	9 5/8	11 1/8	12 3/4	7 1/16	7 7/8	8 5/8	9 3/8	10 3/16	10 15/16	11 11/16	12 7/16	13 1/4	14	14 3/4	15 1/2	16 5/16	17 1/16	17 13/16
31 - 34			9 5/8	11 1/8	12 3/4	14 3/8	7 7/8	8 5/8	9 3/8	10 3/16	10 15/16	11 11/16	12 7/16	13 1/4	14	14 3/4	15 1/2	16 5/16	17 1/16	17 13/16
35 - 44			10	11 3/8	12 13/16	14 1/4	8 5/8	9 3/8	10 1/8	10 7/8	11 11/16	12 7/16	13 3/16	14	14 3/4	15 1/2	16 5/16	17 1/16	17 13/16	18 9/16
45 - 50				11 3/8	12 13/16	14 1/4	15 5/8	9 3/8	10 1/8	10 7/8	11 11/16	12 7/16	13 3/16	14	14 3/4	15 1/2	16 5/16	17 1/16	17 13/16	18 9/16
51 - 55				11 13/16	13 1/8	14 7/16	15 3/4	17	11	11 13/16	12 9/16	13 5/16	14 1/16	14 7/8	15 5/8	16 3/8	17 3/16	17 15/16	18 11/16	19 7/16
56 - 57					13 1/8	14 7/16	15 3/4	17	18 5/16	11 13/16	12 9/16	13 5/16	14 1/16	14 7/8	15 5/8	16 3/8	17 3/16	17 15/16	18 11/16	19 7/16
58 - 60					13 1/2	14 11/16	15 15/16	17 1/8	11 7/8	12 11/16	13 7/16	14 3/16	14 15/16	15 3/4	16 1/2	17 1/4	18	18 13/16	19 9/16	20 5/16
61 - 62						14 5/8	15 13/16	16 15/16	18 1/8	19 1/4	13 7/16	14 3/16	14 15/16	15 3/4	16 1/2	17 1/4	18	18 13/16	19 9/16	20 5/16
63 - 66						14 11/16	15 3/4	16 7/8	18	19 1/8	14 3/16	14 15/16	15 3/4	16 1/2	17 1/4	18	18 3/4	19 1/2	20 5/16	21 1/16
67 - 70						15 7/8	17	18 1/16	20 3/8	20 1/4	21 1/2	15 13/16	16 9/16	17 3/8	18 1/8	18 7/8	19 5/8	20 7/16	21 3/16	21 15/16
71 - 72						15 7/8	17	18 1/8	19 1/4	20 3/8	21 1/2	22 9/16	16 9/16	17 3/8	18 1/8	18 7/8	19 5/8	20 7/16	21 3/16	21 15/16
73 - 74						15 7/8	17	18 1/8	19 1/4	20 3/8	21 1/2	22 9/16	16 9/16	17 3/8	18 1/8	18 7/8	19 5/8	20 7/16	21 3/16	21 15/16

SHORT TRAVEL

STANDARD TRAVEL

DIMENSION "D" (MAXIMUM)

SIZE	TOTAL TRAVEL (IN)																			
	1 1/2	2	3	4	5	6	7	8	9	10	11	12	13	14	15	16	17	18	19	20
1 - 9	20 5/16	20 13/16	21	21 5/8	22 1/4	22 15/16	23 9/16	24 3/16	24 13/16	25 1/2	26 1/8	26 3/4	27 7/16	28 1/16	28 11/16	29 3/8	30	30 5/8	31 1/4	31 15/16
10 - 24		24 7/8	25 7/8	25 9/16	26 3/16	26 7/8	27 1/2	28 1/8	28 3/4	29 7/16	30 1/16	30 3/4	31 3/8	32	32 5/8	33 5/16	33 15/16	34 9/16	35 3/16	35 7/8
25 - 30		28 3/8	30 1/16	31 11/16	33 3/8	29 9/16	30 3/16	30 13/16	31 3/4	32	32 5/8	34 13/16	34 13/16	34 11/16	35 5/16	36	36 5/8	37 1/4	37 15/16	38 9/16
31 - 34			32 1/8	33 3/4	35 7/16	37 1/16	32 1/8	32 3/4	33 7/16	34 1/16	34 11/16	35 5/16	36	36 5/8	37 1/4	37 15/16	38 9/16	39 3/16	39 13/16	40 1/2
35 - 44			39 9/16	40 7/8	42 3/16	43 1/2	40 1/4	40 7/8	41 9/16	42 3/16	42 13/16	43 7/16	44 1/8	44 3/4	45 3/8	46 1/16	46 11/16	47 3/16	48	48 5/8
45 - 50				45 5/8	46 15/16	48 1/4	49 9/16	46 1/8	46 13/16	47 7/16	48 1/16	48 11/16	49 3/8	50	50 5/8	51 5/16	51 15/16	52 9/16	53 3/16	53 7/8
51 - 55				47 1/4	48 3/8	49 9/16	50 11/16	51 13/16	49 3/8	50	50 5/8	51 1/4	51 15/16	52 9/16	53 3/16	53 7/8	54 1/2	55 1/8	55 3/4	56 7/16
56 - 57					51 3/4	52 7/8	54 1/16	55 3/16	56 5/16	53 5/8	54 1/4	54 3/4	55 7/16	56 3/16	56 13/16	57 1/2	58 1/8	58 3/4	59 3/8	60
58 - 60					54 9/16	55 9/16	56 9/16	57 9/16	56 1/16	56 11/16	57 5/16	57 15/16	58 5/8	59 1/4	59 7/8	60 9/16	61 3/16	61 13/16	62 1/2	63 1/8
61 - 62						58	58 15/16	59 7/8	60 13/16	61 3/4	59 7/16	60 1/16	60 3/4	61 3/8	62	62 11/16	63 5/16	63 15/16	64 5/8	65 1/4
63 - 66						64 1/16	64 15/16	65 13/16	66 1/16	69 7/16	68 7/16	66 9/16	67 1/4	67 7/8	68 1/2	69 3/16	69 13/16	70 3/16	70 13/16	71 1/2
67 - 70						75 13/16	76 11/16	77 1/2	78 3/8	79 1/4	80 1/2	78 3/8	79	79 5/8	80 1/4	80 7/8	81 9/16	82 3/16	82 13/16	83 1/2
71 - 72						84 5/16	85 3/16	86	86 7/8	87 3/4	88 5/8	89 1/2	87 1/2	88 1/8	88 3/4	89 3/8	90 1/16	90 11/16	91 3/8	92
73 - 74						82 7/16	81 5/8	83 5/16	84 1/8	85	85 7/8	86 3/4	85 7/8	86 1/4	86 7/8	87 1/2	88 5/16	88 13/16	89 1/2	90 1/8

SHORT TRAVEL

STANDARD TRAVEL

SIZE	SHORT TRAVEL (IN)				STANDARD TRAVEL (IN)			
	TOTAL TRAVEL (IN)	W (IN)	a (deg)	TRAV. ARC (deg)	TOTAL TRAVEL (in)	W (IN)	a (deg)	b (deg)
1 - 9	1 1/2 - 2 3/8	1.57 x T	40	40	2 1/2 - 10	T	40	60
10 - 24	2 - 3 7/8	1.57 x T	40	40	4 - 10	T	40	60
25 - 30	2 - 5 7/8	2.29 x T	46	24	6 - 11	T	40	60
31 - 34	3 - 6 7/8	2.29 x T	46	24	7 - 14	T	40	60
35 - 44	3 - 6 3/8	1.93 x T	43	30	6 1/2 - 14	T	40	60
45 - 50	4 - 7 7/8	1.93 x T	43	30	8 - 14	T	40	60
51 - 55	4 - 8 3/8	1.72 x T	41	35	8 1/2 - 14	T	40	60
56 - 57	5 - 9 3/8	1.72 x T	41	35	9 1/2 - 14	T	40	60
58 - 60	5 - 8 7/8	1.57 x T	40	40	9 - 14	T	40	60
61 - 62	6 - 10 7/8	1.49 x T	39	43	11 - 18	T	40	60
63 - 66	6 - 10 7/8	1.41 x T	38	45	11 - 18	T	40	60
67 - 70	6 - 11 7/8	1.41 x T	38	45	12 - 20	T	40	60
71 - 72	6 - 12 7/8	1.41 x T	38	45	13 - 20	T	40	60
73 - 74	6 - 12 7/8	1.41 x T	38	45	13 - 20	T	40	60

These dimensions may be interpolated, except across short and standard travel separation line.



EQUALBALANCE™ CONSTANT EFFORT SUPPORTS

VB TYPE VERTICAL BASE

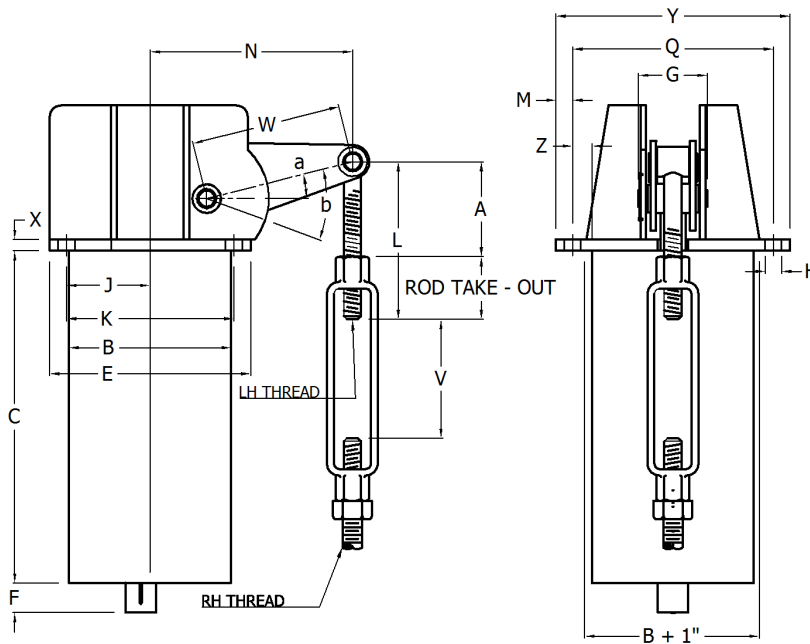

The vertical VB-type EQUALBALANCE™ base-type hanger is designed for use when dimensional limitations restrict the use of a horizontal type hanger. The VB-type EQUALBALANCE™ hanger may be mounted on top of the supporting steel or two units may be inverted and used in a trapeze configuration, as shown on the applications page. Attachment to the structure may be made by either bolting or welding. The VB-type EQUALBALANCE™ is available for loads from 10 lbs through 37,501 lbs and for total travels from 1 1/2 through 20 inches.

SIZE	TOTAL TRAVEL (IN)	STD. ROD DIA. (IN)	B (IN)	C (IN)	E (IN)	F (IN)	G (IN)	H (IN)	J (IN)	K (IN)	M (IN)	Q (IN)	X (IN)	Y (IN)	Z (IN)	APPROX UNIT WEIGHT (LBS.)
1 - 9	3 - 20	1/2 & 5/8	5 9/16	10 5/8	8	3 11/16	2 15/16	9/16	3 1/4	6 1/2	3/4	9	1/4	10 1/2	1	40
10 - 24	3 - 4 7/8	1/2 - 3/4	9 5/8	13 3/8	11	4 1/4	4 3/16	9/16	4 1/4	8 1/2	3/4	12	1/2	13 1/2	1	170
	5 - 20	1/2 - 3/4														
25 - 30	3 - 6	5/8 - 1	11 3/4	14	13 1/2	4 5/8	4 5/8	11/16	5 1/2	11	1	15 1/2	3/4	17 1/2	1 1/4	275
	6 1/4 - 20	1/2 - 3/4														
31 - 34	3 1/2 - 8 1/8	3/4 - 1 1/4	12 3/4	14 3/4	16 1/4	5 1/16	4 5/8	11/16	6 1/4	12 1/2	1	17 1/2	3/4	19 1/2	1 1/4	310
	8 1/4 - 20	1/2 - 1														
35 - 44	3 1/2 - 7 1/8	1 - 1 1/2	14	21 1/8	16 1/4	6 1/8	6 3/16	15/16	6 1/4	12 1/2	1 3/8	17 5/8	1	20 3/8	1 1/4	450
	7 1/4 - 20	5/8 - 1 1/4														
45 - 50	4 - 8 5/8	1 1/4 - 1 3/4	14	25	17 1/2	6 1/2	6 1/4	15/16	6 3/4	13 1/2	1 1/2	19	1	22	1 1/2	550
	8 3/4 - 20	1 - 1 1/4														
51 - 55	5 - 8 5/8	1 1/4 - 2	16	25 7/8	19 1/2	7	7	15/16	7 1/2	15	1 1/2	22 1/4	1	25 1/4	1 1/2	905
	8 3/4 - 20	1 - 1 1/2														
56 - 57	6 - 9 7/8	1 1/2 - 2	18	28 1/8	21 3/4	7 1/4	8 7/8	1 1/16	8	16	1 3/4	25	1 1/4	28 1/2	2	1010
	10 - 20	1 1/4 - 1 1/2														
58 - 60	6 - 8 7/8	1 3/4 - 2 1/4	18	30	22	7 7/8	8 7/8	1 1/16	8	16	1 3/4	25 1/4	1 1/4	28 3/4	2	1155
	9 - 20	1 1/4 - 1 3/4														
61 - 62	6 - 12 7/8	1 3/4 - 2 1/4	18	30 3/4	26	8 3/8	10	1 1/4	8 1/2	17	1 7/8	28 1/8	1 1/4	31 7/8	2 1/2	1600
	13 - 20	1 1/4 - 1 3/4														
63 - 66	6 - 11 7/8	1 3/4 - 2 3/4	22	35 5/8	26	8 3/4	10	1 3/8	9 1/2	19	2	30	1 1/4	34	2 1/2	2400
	12 - 20	1 1/2 - 2														



EQUALBALANCE™ CONSTANT EFFORT SUPPORTS

VB TYPE

VERTICAL BASE

DIMENSION "A"

SIZE	TOTAL TRAVEL (IN)																		
	3	4	5	6	7	8	9	10	11	12	13	14	15	16	17	18	19	20	
1 - 9	3 11/16	4 5/16	5	5 5/8	6 1/4	6 15/16	7 1/2	8 3/16	8 13/16	9 1/2	10 1/8	10 3/4	11 3/8	12 1/16	12 11/16	13 5/16	14	14 5/8	
10 - 24	5 1/16	6 1/16	5 5/16	6	6 5/8	7 1/4	7 15/16	8 9/16	9 3/16	9 13/16	10 1/2	11 1/8	11 3/4	12 3/8	13 1/16	13 11/16	14 3/8	15	
25 - 30	7 7/16	9 1/8	10 3/4	12 3/8	7 9/16	8 3/16	8 7/8	9 1/2	10 1/8	10 3/4	11 7/16	12 1/16	12 11/16	13 3/8	14	14 5/8	15 5/16	15 15/16	
31 - 34	8 5/8	9 7/16	11 1/8	12 3/4	14 3/8	16 1/16	9 1/8	9 3/4	10 3/8	11 1/16	11 11/16	12 5/16	12 15/16	13 9/16	14 1/4	14 7/8	15 9/16	16 3/16	
35 - 44	7 5/16	8 5/8	10	11 1/4	12 9/16	8 5/8	9 5/16	9 15/16	10 9/16	11 1/4	11 7/8	12 1/2	13 1/8	13 13/16	14 7/16	15 1/16	15 3/4	16 3/8	
45 - 50		8 5/8	10	11 1/4	12 9/16	13 15/16	9 3/4	10 7/16	11 1/16	11 3/4	12 3/8	13	13 5/8	14 1/4	14 15/16	15 9/16	16 1/4	16 7/8	
51 - 55			9 1/2	10 5/8	11 3/4	12 7/8	10 1/2	11 1/8	11 3/4	12 7/16	13 1/16	13 11/16	14 5/16	15	15 5/8	16 1/4	16 7/8	17 9/16	
56 - 57				10 7/8	12	13 1/8	14 5/16	11 5/8	12 1/4	12 15/16	13 9/16	14 3/16	14 13/16	15 1/2	16 1/8	16 3/4	17 7/16	18 1/16	
58 - 60				10 11/16	11 11/16	12 11/16	11 3/16	11 13/16	12 7/16	13 1/16	13 3/4	14 3/8	15	15 11/16	16 5/16	16 15/16	17 9/16	18 1/4	
61 - 62				10 7/8	11 13/16	12 3/4	13 11/16	14 5/8	15 9/16	16 1/2	13 5/8	14 1/4	14 7/8	15 9/16	16 3/16	16 13/16	17 1/2	18 1/8	
63 - 66				10 1/2	11 5/16	12 13/16	13 1/16	13 15/16	14 13/16	13	13 5/8	14 1/4	14 7/8	15 9/16	16 3/16	16 13/16	17 1/2	18 1/8	

*Dimension "A" is for down travel (cold to hot). For up travel, increase dimension by length of total travel

SHORT TRAVEL

STANDARD TRAVEL

DIMENSION "N" (ARM IN UP POSITION)

SIZE	TOTAL TRAVEL (IN)																		
	3	4	5	6	7	8	9	10	11	12	13	14	15	16	17	18	19	20	
1 - 9	4 13/16	5 9/16	6 5/16	7 1/16	7 7/8	8 5/8	9 3/8	10 3/16	10 15/16	11 11/16	12 7/16	13 1/4	14	14 3/4	15 1/2	16 5/16	17 1/16	17 13/16	
10 - 24	7 5/16	8 9/16	6 5/16	7 1/16	7 7/8	8 5/8	9 3/8	10 3/16	10 15/16	11 11/16	12 7/16	13 1/4	14	14 3/4	15 1/2	16 5/16	17 1/16	17 13/16	
25 - 30	9 9/16	11 1/8	12 3/4	14 3/8	7 7/8	8 5/8	9 3/8	10 3/16	10 15/16	11 11/16	12 7/16	13 1/4	14	14 3/4	15 1/2	16 5/16	17 1/16	17 13/16	
31 - 34	9 9/16	11 1/8	12 3/4	14 3/8	15 15/16	17 9/16	9 3/8	10 3/16	10 15/16	11 11/16	12 7/16	13 1/4	14	14 3/4	15 1/2	16 5/16	17 1/16	17 13/16	
35 - 44	10	11 7/16	12 13/16	14 3/16	15 5/8	9 3/8	10 1/8	10 7/8	11 11/16	12 7/16	13 3/16	14	14 3/4	15 1/2	16 1/4	17 1/16	17 13/16	18 9/16	
45 - 50		11 7/16	12 13/16	14 3/16	15 5/8	17 1/16	10 1/8	10 7/8	11 11/16	12 7/16	13 3/16	14	14 3/4	15 1/2	16 1/4	17 1/16	17 13/16	18 9/16	
51 - 55			13 1/8	14 7/16	15 3/4	17	11	11 13/16	12 9/16	13 5/16	14 1/16	14 7/8	15 5/8	16 3/8	17 3/16	17 15/16	18 11/16	19 7/16	
56 - 57				14 7/16	15 3/4	17	18 5/16	11 13/16	12 9/16	13 5/16	14 1/16	14 7/8	15 5/8	16 3/8	17 3/16	17 15/16	18 11/16	19 7/16	
58 - 60				14 3/4	15 15/16	17 1/8	11 7/8	12 11/16	13 7/16	14 3/16	14 15/16	15 3/4	16 1/2	17 1/4	18	18 13/16	19 9/16	20 5/16	
61 - 62				14 5/8	15 3/4	16 15/16	18 1/8	19 1/4	20 7/16	21 9/16	14 15/16	15 3/4	16 1/2	17 1/4	18	18 13/16	19 9/16	20 5/16	
63 - 66				14 5/8	15 3/4	16 7/8	18	19 1/8	20 1/4	14 15/16	15 3/4	16 1/2	17 1/4	18	18 3/4	19 1/2	20 5/16	21 1/16	

SHORT TRAVEL

STANDARD TRAVEL

DIMENSION "W"

SIZE	SHORT TRAVEL (IN)				STANDARD TRAVEL (IN)			
	TOTAL TRAVEL (IN)	W (IN)	a (deg)	TRAV. ARC (deg) b	TOTAL TRAVEL (IN)	W (IN)	a (deg)	TRAV. ARC (deg) b
1 - 9	-	-	-	-	3 - 10	T	40	60
10 - 24	3 - 4 7/8	1.57 x T	40	40	5 - 10	T	40	60
25 - 30	3 - 6	2.29 x T	46	24	6 1/4 - 11	T	40	60
31 - 34	3 1/2 - 8 1/8	2.29 x T	46	24	8 1/4 - 14	T	40	60
35 - 44	3 1/2 - 7 1/8	1.93 x T	43	30	7 1/4 - 14	T	40	60
45 - 50	4 - 8 5/8	1.93 x T	43	30	8 3/4 - 14	T	40	60
51 - 55	5 - 8 5/8	1.72 x T	41	35	8 3/4 - 14	T	40	60
56 - 57	6 - 9 7/8	1.72 x T	41	35	10 - 14	T	40	60
58 - 60	6 - 8 7/8	1.57 x T	40	40	9 - 14	T	40	60
61 - 62	6 - 12 7/8	1.49 x T	39	43	13 - 18	T	40	60
63 - 66	6 - 11 7/8	1.41 x T	38	45	12 - 18	T	40	60

DIMENSION "L"

SIZE	ROD SIZE										
	1/2	5/8	3/4	1	1 1/4	1 1/2	1 3/4	2	2 1/4	2 1/2	2 3/4
1 - 9	9 11/16	9 15/16									
10 - 24	11	11 1/4	11 1/2	12 1/8							
25 - 30	11 9/16	11 13/16	12 1/16	12 11/16							
31 - 34		12 15/16	13 3/16	13 13/16	14 9/16						
35 - 44		13 13/16	14 1/16	14 11/16	15 7/16	15 15/16					
45 - 50				16 11/16	17 7/16	17 15/16	18 11/16				
51 - 55				16 15/16	17 11/16	18 3/16	18 15/16	19 7/16			
56 - 57					18 11/16	19 3/16	19 15/16	20 7/16			
58 - 60					19 1/4	19 3/4	20 1/2	21	21 3/4		
61 - 62						20 1/2	21 1/4	21 3/4	22 1/2		
63 - 66						21 1/4	22	22 1/2	23 1/4	23 1/2	24 3/8

Dimension "L" to be increased by 3" for 12" gap turnbuckle.



EQUALBALANCE™ CONSTANT EFFORT SUPPORTS

VBS TYPE VERTICAL BASE STANCHION

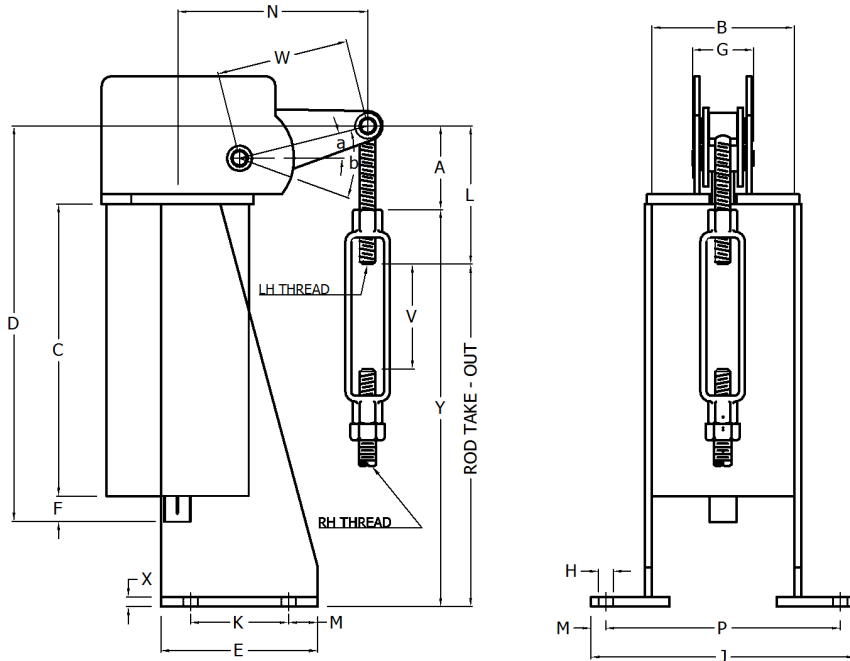

The Type VBS EQUALBALANCE™ vertical base stanchion is designed for use when the footprint of the hanger must be small and the pipe must be supported from below with a strut or from above the supporting structure. The Type VBS EQUALBALANCE™ support may be attached to the supporting structure, either by bolting or welding. The Type VBS EQUALBALANCE™ support is available for loads from 19 lbs through 37,501 lbs and travels from 1 ½ through 20 inches.

SIZE	TOTAL TRAVEL (IN)	B (IN)	C (IN)	E (IN)	F (IN)	G (IN)	H (IN)	J (IN)	K (IN)	M (IN)	P (IN)	S (IN)	X (IN)	Y (IN)	APPROX. UNIT WEIGHT (LBS.)
1 - 9	3 - 10	5 9/16	10 7/8	7 3/4	3 11/16	2 15/16	9/16	11	6 1/2	5/8	9 3/4	1/2	1/4	16 5/16	42
10 - 24	3 - 10	9 5/8	13 7/8	9 3/4	4 1/4	4 3/16	9/16	14	8 1/2	5/8	12 3/4	7/8	1/2	20 1/4	160
25 - 30	3 - 11	11 3/4	14 11/16	13	4 5/8	4 5/8	11/16	18 1/2	11	1	16 1/2	1 1/8	3/4	20 3/4	210
31 - 34	3 1/2 - 14	12 3/4	15 1/2	14 1/2	5 1/16	4 5/8	11/16	22 3/4	12 1/2	1	20 3/4	1 3/8	3/4	22 1/2	280
35 - 44	3 1/2 - 14	14	22 1/8	15 1/4	6 1/8	6 1/4	15/16	23	12 1/2	1 3/8	20 1/4	1 3/4	1	29 7/8	460
45 - 50	4 - 14	14	25 15/16	16 1/2	6 1/2	6 1/2	15/16	23	13 1/2	1 1/2	20	2	1	34	700
51 - 55	5 - 14	16	26 7/8	18	7	7	15/16	28 1/4	15	1 1/2	25 1/4	2	1	35 3/8	840
56 - 57	6 - 14	18	29 3/8	19 1/2	7 1/4	8 7/8	1 1/16	29 1/2	16	1 3/4	26	2 1/2	1 1/4	38 3/8	1130
58 - 60	6 - 14	18	31 1/8	19 1/2	7 7/8	8 7/8	1 1/16	30 1/2	16	1 3/4	27	2 1/2	1 1/4	40 3/8	1365
61 - 62	6 - 18	18	31 13/16	20 3/4	8 3/8	10	1 1/4	33 1/2	17	1 7/8	29 3/4	2 3/4	1 1/4	41 5/8	1800
63 - 66	6 - 18	22	35 13/16	23	8 3/4	10	1 3/8	34	19	2	30	2 3/4	1 1/2	47 1/8	2715



EQUALBALANCE™ CONSTANT EFFORT SUPPORTS

VBS TYPE

VERTICAL BASE STANCHION

DIMENSION "A"

SIZE	TOTAL TRAVEL (IN)															
	3	4	5	6	7	8	9	10	11	12	13	14	15	16	17	18
1 - 9	3 7/16	4 1/16	4 11/16	5 3/8	6	6 5/8	7 5/16	7 15/16								
10 - 24	4 1/2	4 3/16	4 13/16	5 1/2	6 1/8	6 3/4	7 7/16	8 1/16								
25 - 30	6 11/16	8 5/16	10	6 3/16	6 13/16	7 7/16	8 1/8	8 3/4	9 3/8							
31 - 34	7 1/16	8 11/16	10 3/8	12	7 1/16	7 11/16	8 3/8	9	9 5/8	10 1/4	10 15/16	11 9/16				
35 - 44	6 5/16	7 5/8	8 15/16	10 1/4	7	7 5/8	8 5/16	8 15/16	9 9/16	10 3/16	10 7/8	11 1/2				
45 - 50		7 5/8	8 15/16	10 1/4	11 5/8	8 1/8	8 13/16	9 7/16	10 1/16	10 11/16	11 3/8	12				
51 - 55			8 1/2	9 5/8	10 3/4	11 15/16	9 1/2	10 1/8	10 3/4	11 3/8	12 1/16	12 11/16				
56 - 57				9 5/8	10 3/4	11 15/16	13	10 3/8	11	11 5/8	12 5/16	12 15/16				
58 - 60				9 7/16	10 7/16	11 7/16	9 15/16	10 9/16	11 3/16	11 13/16	12 1/2	13 1/8				
61 - 62				9 5/8	10 9/16	11 1/2	12 7/16	13 3/8	11 1/16	11 11/16	12 3/8	13	13 5/8	14 1/4	14 15/16	15 9/16
63 - 66				9 3/16	10 1/16	10 15/16	11 13/16	12 11/16	11 1/16	11 11/16	12 3/8	13	13 5/8	14 1/4	14 15/16	15 9/16

*Dimension "A" is for down travel (cold to hot). For up travel, Increase dimension by length of total travel

SHORT TRAVEL

STANDARD TRAVEL

DIMENSION "D"

SIZE	TOTAL TRAVEL (IN)															
	3	4	5	6	7	8	9	10	11	12	13	14	15	16	17	18
1 - 9	18	18 5/8	19 1/4	19 15/16	20 9/16	21 3/16	21 7/8	22 1/2								
10 - 24	22 5/8	22 5/16	22 15/16	23 5/8	24 1/4	24 7/8	25 9/16	26 3/16								
25 - 30	26	27 5/8	29 5/16	25 1/2	26 1/8	26 3/4	27 7/16	28 1/16	28 11/16							
31 - 34	27 5/8	29 1/4	30 15/16	32 9/16	27 5/8	28 1/4	28 15/16	29 9/16	30 3/16	30 13/16	31 1/2	32 1/8				
35 - 44	34 9/16	35 7/8	37 3/16	38 1/2	35 1/4	35 7/8	36 9/16	37 3/16	37 13/16	38 7/16	39 1/8	39 3/4				
45 - 50		40 1/16	41 3/8	42 11/16	39 7/8	40 9/16	41 1/4	41 7/8	42 1/2	43 1/8	43 13/16	44 7/16				
51 - 55			42 3/8	43 1/2	44 5/8	45 13/16	43 3/8	44	44 5/8	45 1/4	45 15/16	46 9/16				
56 - 57				46 1/4	47 3/8	48 9/16	49 5/8	47	47 5/8	48 1/4	48 15/16	49 9/16				
58 - 60				48 7/16	49 7/16	50 7/16	48 15/16	49 9/16	50 3/16	50 13/16	51 1/2	52 1/8				
61 - 62				49 13/16	50 3/4	51 11/16	52 5/8	53 9/16	51 1/4	51 7/8	52 9/16	53 3/16	53 13/16	54 7/16	55 1/8	55 3/4
63 - 66				53 3/4	54 5/8	52 1/2	56 3/8	57 1/4	55 5/8	56 1/4	56 15/16	57 9/16	58 3/16	58 13/16	59 1/2	60 1/8

SHORT TRAVEL

STANDARD TRAVEL

DIMENSION "N" (ARM IN UP POSITION)

SIZE	TOTAL TRAVEL (IN)															
	3	4	5	6	7	8	9	10	11	12	13	14	15	16	17	18
1 - 9	4 13/16	5 9/16	6 5/16	7 1/16	7 7/8	8 5/8	9 3/8	10 3/16								
10 - 24	7 5/16	5 9/16	6 5/16	7 1/16	7 7/8	8 5/8	9 3/8	10 3/16								
25 - 30	9 9/16	11 1/8	12 3/4	7 1/16	7 7/8	8 5/8	9 3/8	10 3/16	10 15/16							
31 - 34	10 3/8	11 1/8	12 3/4	14 3/8	7 7/8	8 5/8	9 3/8	10 3/16	10 15/16	11 11/16	12 7/16	13 1/4				
35 - 44	13 1/4	11 7/16	12 13/16	14 3/16	8 5/8	9 3/8	10 1/8	10 7/8	11 11/16	12 7/16	13 3/16	14				
45 - 50		11 7/16	12 13/16	14 3/16	15 5/8	9 3/8	10 1/8	10 7/8	11 11/16	12 7/16	13 3/16	14				
51 - 55			13 1/8	14 7/16	15 3/4	17	11	11 13/16	12 9/16	13 5/16	14 1/16	14 7/8				
56 - 57				14 7/16	15 3/4	17	18 5/16	11 13/16	12 9/16	13 5/16	14 1/16	14 7/8				
58 - 60				14 3/4	15 15/16	17 1/8	11 7/8	12 11/16	13 7/16	14 3/16	14 15/16	15 3/4				
61 - 62				14 5/8	15 3/4	16 15/16	18 1/8	19 1/4	13 7/16	14 3/16	14 15/16	15 3/4	16 1/2	17 1/4	18	18 13/16
63 - 66				14 5/8	15 3/4	16 7/8	18	19 1/8	14 3/16	14 15/16	15 3/4	16 1/2	17 1/4	18	18 3/4	19 1/2

SHORT TRAVEL

STANDARD TRAVEL

DIMENSION "W"

SIZE	SHORT TRAVEL (IN)				STANDARD TRAVEL (IN)			
	TOTAL TRAVEL (IN)	W (IN)	a (deg)	TRAV. ARC (deg) b	TOTAL TRAVEL (IN)	W (IN)	a (deg)	TRAV. ARC (deg) b
1 - 9	-	-	-	-	3 - 10	T	40	60
10 - 24	3 - 3 7/8	1.57 x T	40	40	4 - 10	T	40	60
25 - 30	3 - 5 7/8	2.29 x T	46	24	6 - 11	T	40	60
31 - 34	3 1/2 - 6 7/8	2.29 x T	46	24	7 - 14	T	40	60
35 - 44	3 1/2 - 6 3/8	1.93 x T	43	30	6 1/2 - 14	T	40	60
45 - 50	4 - 7 7/8	1.93 x T	43	30	8 - 14	T	40	60
51 - 55	5 - 8 3/8	1.72 x T	41	35	8 1/2 - 14	T	40	60
56 - 57	6 - 9 3/8	1.72 x T	41	35	9 1/2 - 14	T	40	60
58 - 60	6 - 8 7/8	1.57 x T	40	40	9 - 14	T	40	60
61 - 62	6 - 10 7/8	1.49 x T	39	43	11 - 18	T	40	60
63 - 66	6 - 10 7/8	1.41 x T	38	45	11 - 18	T	40	60

These dimensions may be interpolated, except across short and standard travel separation line.

Dimension "A" is for down travel (cold to hot), For up travel, decrease dimension by length of total travel.

For 3 1/2" total travel.



EQUALBALANCE™ CONSTANT EFFORT SUPPORTS

U TYPE UPTHRUST

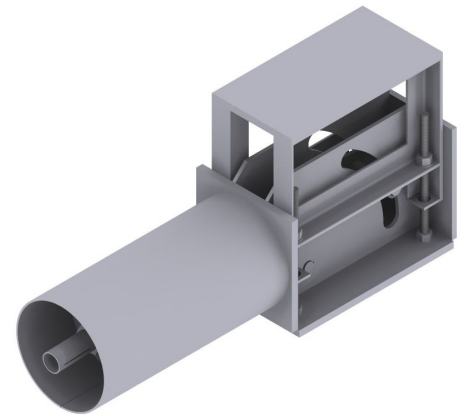
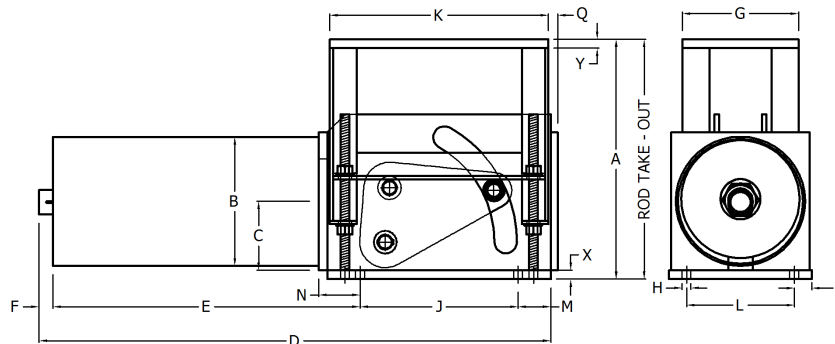

The Upthrust support is designed for use when the pipe must be supported from below and when there is room to extend the casing horizontally. The Type U EQUALBALANCE™ Upthrust support may be attached to the supporting structure or foundation, by either bolting or welding. Generally, a low friction slide bearing is supplied on the top of the load table so that the member being supported by the Upthrust support can move laterally with minimal resistance. Vertical alignment of the load table is maintained by PTFE slide bearings during support movement. The Type U EQUALBALANCE™ Upthrust support is available for loads from 34 lbs through 20,117 lbs and total travels from 1 ½ through 12 inches.

SIZE	TOTAL TRAVEL (IN)	B (IN)	MAX. D (IN)	E (IN)	F (IN)	G (IN)	H (IN)	J (IN)	K (IN)
1 - 9	1 1/2 - 6	5 9/16	24 15/16	12 1/4	3 11/16	8	9/16	6	9
10 - 24	2 - 6	9 5/8	29	15 1/2	4 1/4	10	9/16	6	10
25 - 30	2 1/2 - 8	11 3/4	33 3/8	16 1/2	4 5/8	13	11/16	8	12 1/2
31 - 34	2 1/2 - 8	12 3/4	35 1/16	17 1/2	5 1/16	13	13/16	8	13
35 - 44	3 - 10	14	45 3/8	24 5/8	6 1/8	15	13/16	10	14 3/4
45 - 50	3 - 10	14	50 1/2	29	6 1/2	15	13/16	10	16
51 - 55	3 1/2 - 12	16	53 7/8	30 1/16	7	17 1/2	1 1/8	15	18
56 - 57	4 - 12	18	59 1/4	32 13/16	7 3/8	19 7/8	1 1/8	15 1/2	20
58 - 60	4 1/2 - 12	18	62 1/8	34 7/8	7 7/8	20 1/4	1 1/8	16	20 1/2

SIZE	L (IN)	M (IN)	N (IN)	P (IN)	Q (IN)	X (IN)	Y (IN)	APPROX. WEIGHT
								NET
1 - 9	6 3/8	2 3/8	1 3/8	13/16	3/8	1/4	1/2	50
10 - 24	8	3 1/4	1 5/8	1	7/16	1/2	3/4	195
25 - 30	9 3/4	4 1/4	1 13/16	1 1/2	3/4	5/8	3/4	335
31 - 34	10 1/2	4 1/2	2 1/16	1 1/2	3/4	3/4	3/4	405
35 - 44	12 1/8	4 5/8	2 1/2	1 1/8	1 3/16	3/4	1	640
45 - 50	12 3/8	5	3	1 13/16	1	1	1	850
51 - 55	13 1/2	1 13/16	3 3/16	2 1/4	1	1 1/4	1 1/4	950
56 - 57	16 1/2	3 9/16	3 7/16	2 1/4	1 1/4	1 1/4	1 1/4	1290
58 - 60	16 1/2	3 3/8	3 5/8	2 1/4	1 1/4	1 1/4	1 1/4	1560



EQUALBALANCE™ CONSTANT EFFORT SUPPORTS

U TYPE (Continued)

UPTHRUST

DIMENSION "C"

SIZE	TOTAL TRAVEL (IN)										
	1 1/2	2	2 1/2	3	3 1/2	4	4 1/2	5	5 1/2	6	6 1/2
1 - 9	5	5 1/2	6	6 1/2	7	7 1/2	8	8 1/2	9	9 1/2	
10 - 24		7 5/8	8 1/8	8 5/8	9 1/8	9 5/8	10 1/8	10 5/8	11 1/8	11 5/8	
25 - 30			9 3/8	9 7/8	10 3/8	10 7/8	11 3/8	11 7/8	12 3/8	12 7/8	13 3/8
31 - 34			10 1/2	11	11 1/2	12	12 1/2	13	13 1/2	14	14 1/2
35 -44				11	11 1/2	12	12 1/2	13	13 1/2	14	14 1/2
45 - 50				11 7/8	12 3/8	12 7/8	13 3/8	13 7/8	14 3/8	14 7/8	15 3/8
51 - 55					13 1/2	14	14 1/2	15	15 1/2	16	16 1/2
56 - 57						14 1/2	15	15 1/2	16	16 1/2	17
58 -60							15 9/16	16 1/16	16 9/16	17 1/16	17 9/16

SHORT TRAVEL

STANDARD TRAVEL

DIMENSION "C"

SIZE	TOTAL TRAVEL (IN)										
	7	7 1/2	8	8 1/2	9	9 1/2	10	10 1/2	11	11 1/2	12
1 - 9											
10 - 24											
25 - 30	13 7/8	14 3/8	14 7/8								
31 - 34	15	15 1/2	16								
35 -44	15	15 1/2	16	16 1/2	17	17 1/2	18				
45 - 50	15 7/8	16 3/8	16 7/8	17 3/8	17 7/8	18 3/8	18 7/8				
51 - 55	17	17 1/2	18	18 1/2	19	19 1/2	20	20 1/2	21	21 1/2	22
56 - 57	17 1/2	18	18 1/2	19	19 1/2	20	20 1/2	21	21 1/2	22	22 1/2
58 -60	18 1/16	18 9/16	19 1/16	19 9/16	20 1/16	20 9/16	21 1/16	21 9/16	22 1/16	22 9/16	23 1/16

DIMENSION "A" *

SIZE	TOTAL TRAVEL (IN)										
	1 1/2	2	2 1/2	3	3 1/2	4	4 1/2	5	5 1/2	6	6 1/2
1 - 9	10 1/4	11 1/4	12 1/4	13 1/4	14 1/4	15 1/4	16 1/4	17 1/4	18 1/4	19 1/4	
10 - 24		15 3/8	16 3/8	17 3/8	18 3/8	19 3/8	20 3/8	21 3/8	22 3/8	23 3/8	
25 - 30			19	20	21	22	23	24	25	26	27
31 - 34			21	22	23	24	25	26	27	28	29
35 -44				22 1/4	23 1/4	24 1/4	25 1/4	26 1/4	27 1/4	28 1/4	29 1/4
45 - 50				23 3/4	24 3/4	25 3/4	26 3/4	27 3/4	28 3/4	29 3/4	30 3/4
51 - 55					27	28	29	30	31	32	33
56 - 57						28 3/8	29 3/8	30 3/8	31 3/8	32 3/8	33 3/8
58 -60							30 7/16	31 7/16	32 7/16	33 7/16	34 7/16

*Dimension "A" is for down travel (cold to hot). For up travel, Increase dimension by length of total travel

SHORT TRAVEL

STANDARD TRAVEL

SIZE	TOTAL TRAVEL (IN)										
	7	7 1/2	8	8 1/2	9	9 1/2	10	10 1/2	11	11 1/2	12
1 - 9											
10 - 24											
25 - 30	28	29	30								
31 - 34	30	31	32								
35 -44	30 1/4	31 1/4	32 1/4	33 1/4	34 1/4	35 1/4	36 1/4				
45 - 50	31 3/4	32 3/4	33 3/4	34 3/4	35 3/4	36 3/4	37 3/4				
51 - 55	34	35	36	37	38	39	40	41	42	43	44
56 - 57	34 3/8	35 3/8	36 3/8	37 3/8	38 3/8	39 3/8	40 3/8	41 3/8	42 3/8	43 3/8	44 3/8
58 -60	35 7/16	36 7/16	37 7/16	38 7/16	39 7/16	40 7/16	41 7/16	42 7/8	43 7/16	44 7/16	45 7/16

*Dimension "A" is for down travel (cold to hot). For up travel, Increase dimension by length of total travel



AAA TECHNOLOGY & SPECIALTIES CO., INC.

6219 Brittmoore Road, Houston, Texas 77041-5114, U.S.A.

Telephone: 713-849-3366; FAX: 713-849-3654

E-mail: info@aaatech.com; Website: <http://www.aaatech.com>

