

AAA TECHNOLOGY & SPECIALTIES CO., INC.

TRI*SLIDE™ LOW FRICTION SLIDE BEARINGS

TOTAL SOLUTION SERVICE
For the Industrial Piping Marketplace

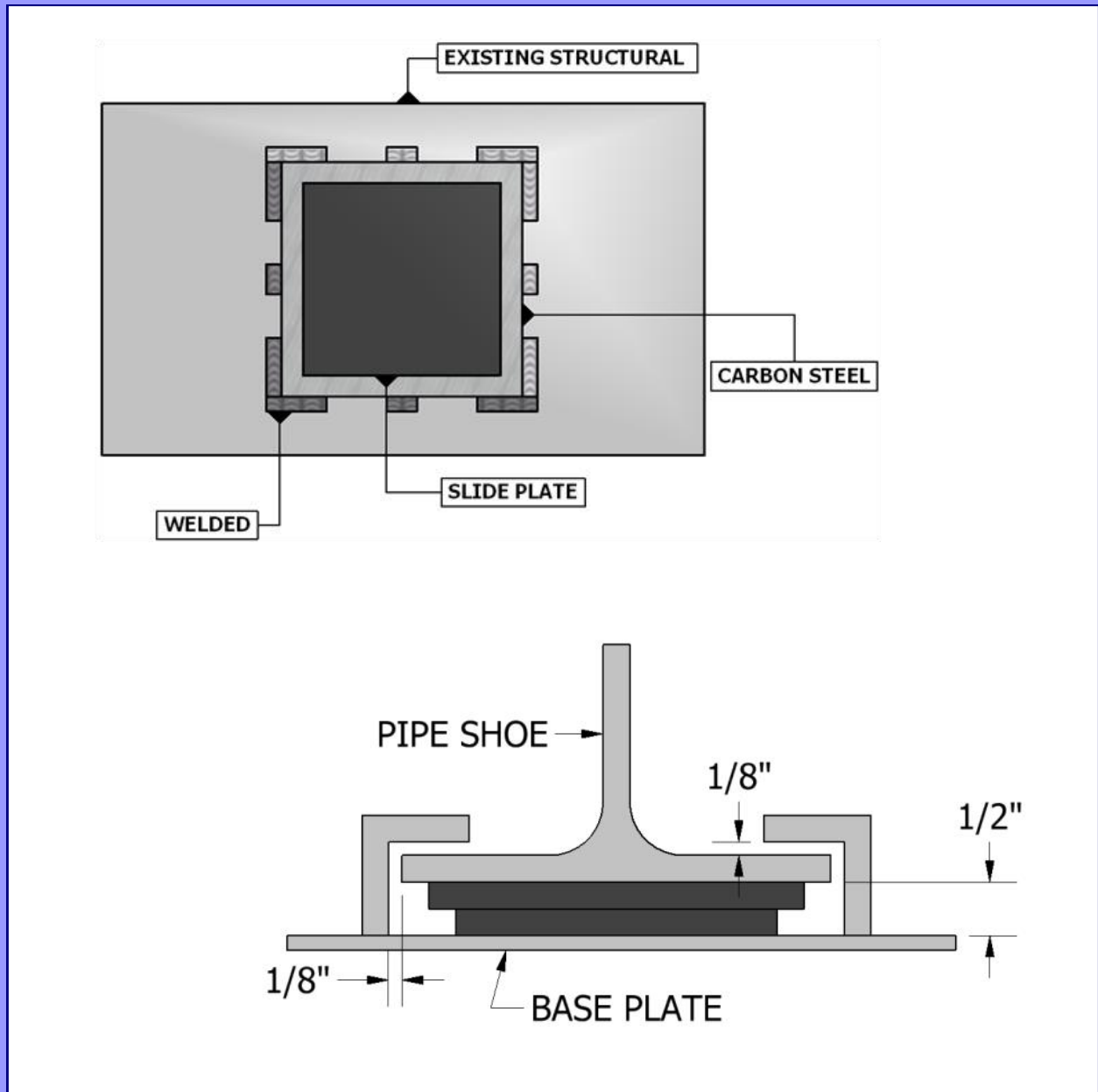

2016-1

www.aaatech.com

SERVING INDUSTRY SINCE 1971

All Rights Reserved © 2020 AAA Technology and Specialties Co., Inc.



TRI*SLIDE™ LOW FRICTION SLIDE BEARINGS

Select the CORRECT Low Friction Slide Bearing for your Application

First, what is a Low Friction Slide Bearing and why should one be used?

TRI*SLIDE™ bearings function as follows:

- ◆ Provide support to the piping system or equipment at that location.
- ◆ Provide minimal resistance along the sliding surfaces as motion occurs.
- ◆ Isolate the piping system or equipment at that location from the support member. Isolation can be thermal to some extent, galvanic and can be electrical as well as structural.
- ◆ Provide a seismic separation between the piping system or equipment and the support member at that location.

Second, what factors do I consider when selecting a Low Friction Slide Bearing?

- ◆ Service Temperature is a major factor in selecting the correct bearing for an application
- ◆ Environment should be considered in the selection process
 - Acidic or Basic
 - Exposed to continuous liquid flow
 - Exposed to UV rays (sunlight)
- ◆ Amount of relative movement to between the piping system or equipment and the support member

Service Temperature

- ◆ For Service Temperatures from cryogenic range to 300 deg F (149 deg C), our TF2 or TFSS slide bearings are recommended. Whenever possible, the upper bearing should cover the lower bearing in order to prevent UV degradation.
- ◆ For Service Temperatures from 300 deg F (149 deg C) to 750 deg F (399 deg C), our Graphite-S slide bearings are suitable for use.
- ◆ For Service Temperatures from 300 deg F (149 deg C) to 800 deg F (427 deg C), our Self-lubricating Bronze slide bearings are suitable for use.
- ◆ For Service Temperatures from 300 deg F (149 deg C) to 1,200 deg F (649 deg C), our Graphite-HT slide bearings are suitable for use.
- ◆ For Service Temperatures from 500 deg F (260 deg C) to 1,600 deg F (871 deg C), our Self-lubricating Meehanite slide bearings are suitable for use. For these high temperature applications, AAA Technology's staff works closely with the Meehanite Corporation's team of experts to use the appropriate grade of Meehanite for each unique application.

The upper bearing should, whenever possible, cover the lower

bearing in order to prevent the build-up of grit and grime on the lower bearing surface.

Service Temperatures - Cryogenic to 300 deg F (149 deg C)

General Specifications - PTFE - TRI*SLIDE™ bearings are made of glass filled PTFE bonded to a steel backing plate. TRI*SLIDE™ bearings are designed to reduce frictional resistance to movement at support or restraint points in piping systems and process equipment. When utilized properly, TRI*SLIDE™ bearings will not show any significant wear during the expected life of the associated piping system.

TRI*SLIDE™ bearings are available in two basic styles for normal applications.

◆ Type TF2 (75 psi to 2,000 psi)

Type TF2 is designed for applications where PTFE to PTFE slide bearing surfaces are desired. The Type TF2 Slide bearing consists of a 3/32" thick upper and lower PTFE slide bearing element. These slide bearing elements are typically bonded to 10 gauge carbon steel backing plates. The standard process industry practice is to make the upper element larger than the lower element by slightly more than the expected maximum movement. In fact, the practice is to insure that the bottom element is never left uncovered by the upper element.

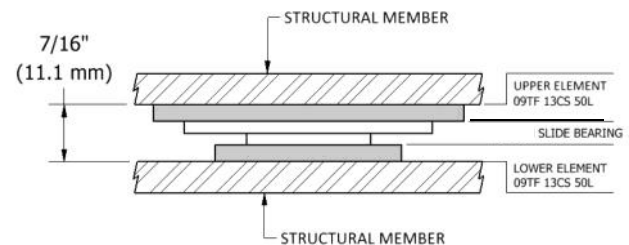

APPLICATION EXAMPLE



◆ Type TFSS (2,000 psi to 4,000 psi)

Type TFSS is designed for application where a polished stainless steel plate (upper bearing) moves across a PTFE member (lower slide bearing). The upper element is made of a polished Stainless Steel plate (in some instances, a 20 gauge SS plate is welded to a 10ga carbon steel backing plate and in other instances, a polished SS upper plate is provided) and the lower element is made of a 3/32" thick PTFE slide bearing bonded to a 10 gauge



TRI*SLIDE™ LOW FRICTION SLIDE BEARINGS

carbon steel backing plate. As with Type TF2, the standard process industry practice is to make the stainless steel upper element larger than the lower PTFE slide bearing element by slightly more than the expected maximum movement.

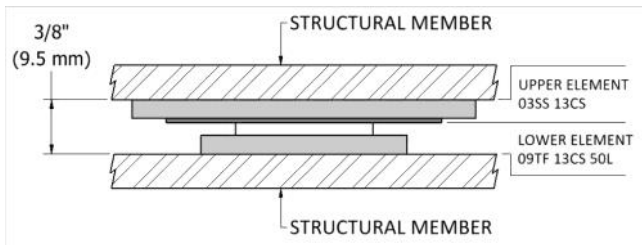

APPLICATION EXAMPLE

Type F Spring Support with a polished Stainless Steel bearing over PTFE

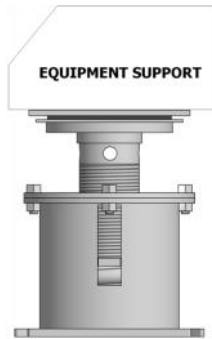

Sizing for Loads and Movements

The lower element should be sized for the load and the upper element should be sized for the movement. To design the lower slide bearing element, divide the load carried by the slide bearing element by the allowable pressure given in the following "Bearing Load" charts. For type TF2 the allowable pressure range should be between 75 psi and 2000 psi; for Type TFSS, the allowable pressure range should be between 2000 psi to 4000 psi. For example, for a Type TF2 slide bearing carrying 5,000 pounds, the size of the bearing in square inches could be:

$$5,000 \text{ lbs.} / 75 \text{ lbs./in}^2 = 66.6 \text{ in}^2$$

or

$$5,000 \text{ lbs.} / 2,000 \text{ lbs./in}^2 = 2.5 \text{ in}^2$$

For Type TF2, many designers typically use between 500 psi and 1000 psi giving a slide bearing between 10 in² and 5 in² to carry the 5,000 lb. load. For Type TFSS, many designers typically use between 2500 psi and 3000 psi giving a slide bearing 2 in² and 1.67 in² to carry the same 5,000 lb. load. Note also that as the temperature increases, the load carrying capacity of the slide bearing decreases.

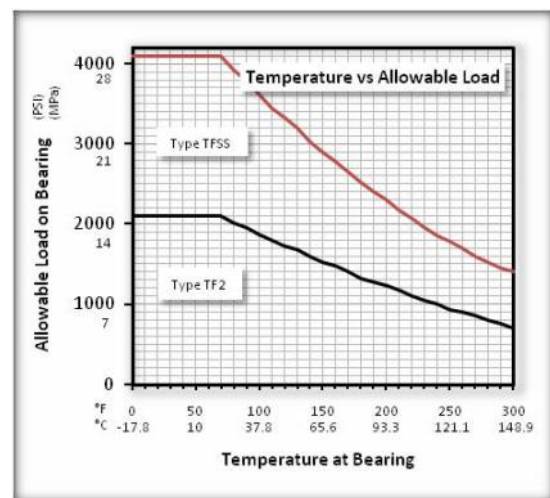
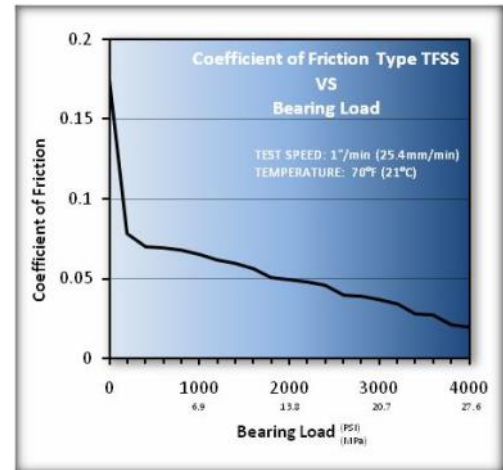
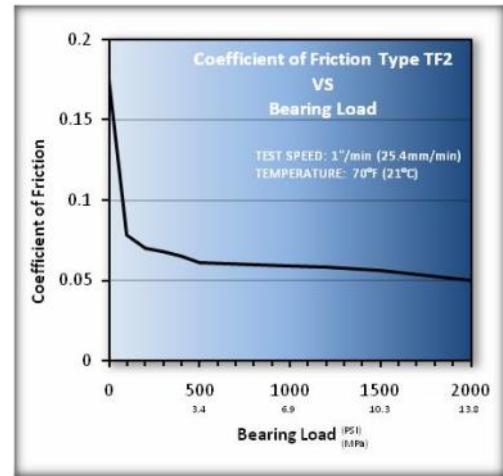

To properly size the upper slide bearing element, adhere to the following procedure:

1. Start with the size you have determined to be required for the lower element.



TRI*SLIDE™ LOW FRICTION SLIDE BEARINGS

- To the width required for load, add two times the lateral movement expected. Then add 1" or twenty (20) percent of the lateral movement, whichever is greater.
- To the length required for load, add two times the axial movement expected. Then add 1" or twenty (20) percent of the axial movement. Whichever is greater.

For both the upper and lower slide bearing elements, AAA Technology recommends a backing plate with a 1/2" lip on all sides. A larger lip can be provided. A smaller lip is not recommended since the slide plates are typically to be welded in place and a smaller lip may lead to separation of the PTFE from the backing plate because of the heat buildup from welding the backing plate to the structure.

Construction Options - Type TF2 Slide Bearing

Standard TF2 slide bearing assemblies are constructed per Table 1 where all thicknesses are specified in hundredths of an inch.

Type TF2 slide bearing options are as follows:

Table 1

Type TF2	Thickness (in)	Material
Upper Slide Surface	.09	PTFE
Upper Backing Plate	10 ga = .13	Carbon Steel = CS
Lower Slide Surface	.09	PTFE
Lower Backing Plate	10 ga = .13	Carbon Steel = CS

- ▲ Slide Bearing Thickness = .09" (3/32" thick)
- ▲ Backing Plate Thicknesses = .25", .38", .50", .75", 1.00"
- ▲ Backing Plate Materials = Stainless Steel (SS), Hot Dip Galvanized Carbon Steel (HDG) & Aluminum (AL).

Construction Options - Type TFSS Slide Bearing

Standard TFSS slide bearing assemblies are constructed per Table 2 where all thicknesses are specified in hundredths of an inch.

Type TFSS slide bearing options are as follows:

Table 2

Type TFSS	Thickness (in)	Material
Upper Slide Surface	.03	Stainless Steel = SS
Upper Backing Plate	10ga = .13	Carbon Steel = CS
Lower Slide Surface	.09	PTFE
Lower Backing Plate	10ga = .13	Carbon Steel = CS

- ▲ Upper Slide Bearing Thickness = .03", .06", .07", .1", .12", .13"

▲ Lower Slide Bearing = other Thicknesses of glass-filled PTFE may be specified or any desired thickness of Virgin PTFE

▲ Backing Plate Thicknesses = .25", .38", .50", .75", 1.00"

▲ Backing Plate Materials = Stainless Steel (SS), Hot Dip Galvanized Carbon Steel (HDG), & Aluminum (AL).

Additional Construction Options

▲ Holes and Slots - If slide bearings are specified at bolted connections, then bolts typically pass through the slide bearings. One slide bearing, typically the upper, will be slotted to allow for movement along the axis of the slots. The other slide bearing will have hole in it to fix the bearing in place while the other slide bearing moves over it.

▲ Studs or Anchors - If stud or anchors are to be welded to the backing plate, specify a backing plate thickness equal to at least the diameter of the stud or anchor.

▲ High Temperature - If the surface temperature at the point of the slide bearing exceeds 300 degree F, see the first page of this brochure for other TRI*SLIDE™ high temperature options.

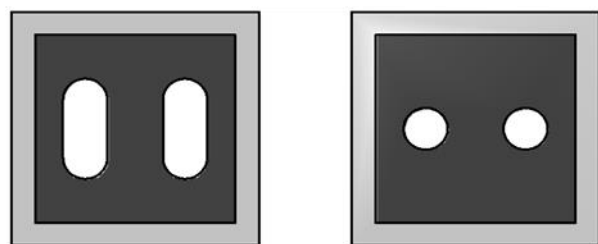
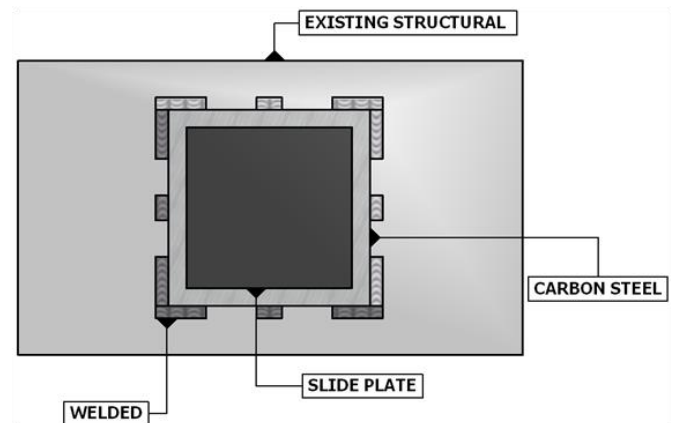

Example of Slots and Holes



TRI*SLIDE™ LOW FRICTION SLIDE BEARINGS

How to Specify Type TF2 TRI*SLIDE™ Slide Bearings

Specify the following items to describe the slide bearings required:

1. Customer Tag Number (Identifier)
2. Type "TF2"
3. Define the Upper Element Properties
 - a. Element - Upper
 - b. Slide Bearing Thickness
 - c. Backing Plate Thickness
 - d. Backing Plate Material
 - e. Width of the Lip
 - f. Out to Out dimensions in inches of the Backing Plate
4. Define the Lower Element Properties
 - a. Element - Lower
 - b. Slide bearing thickness
 - c. Backing plate thickness
 - d. Backing plate material
 - e. Width of lip
 - f. Out-to-out dimensions in inches of the Backing Plate
5. Describe any holes & slots required, if any - tagged sketches should be attached to clarify hole & slot locations & sizes.
6. Describe the studs or anchors required, if any - tagged sketches should be attached to clarify stud & anchor locations & sizes).

For Example:

- ▲ Tag #1 Type TF2
- ▲ U, 09, 13, CS, 50, 9" X 9"
- ▲ L, 09, 13, CS, 50, 6" X 6"

How to Specify Type TFSS TRI*SLIDE™ Slide Bearings

Specify the following items to describe the slide bearings required:

1. Customer Tag Number (Identifier)
2. Type "TFSS"
3. Define the Upper Element Properties
 - a. Element - Upper
 - b. Slide Bearing Thickness
 - c. Backing Plate Thickness
 - d. Backing Plate Material
 - e. Width of the Lip
 - f. Out to Out dimensions in inches of the Backing Plate
4. Define the Lower Element Properties
 - a. Element - Lower
 - b. Slide bearing thickness
 - c. Backing plate thickness
 - d. Backing plate material
 - e. Width of lip

- f. Out to Out dimensions in inches of the Backing Plate

5. Specify Virgin PTFE, if required.
6. Describe any holes and slots required, if any - tagged sketches should be attached to clarify hole and slot locations and sizes.
7. Describe the studs or anchors required, if any - tagged sketches should be attached to clarify stud and anchor locations and sizes.

For Example:

- ▲ Tag #2 Type TFSS
- ▲ U, 03, 13, CS, 50, 9" X 9"
- ▲ L, 09, 13, CS, 50, 6" X 6"

Physical Properties of TRI*SLIDE™ Bearings

◆ Type TF2 Slide Bearings

Type TF2 slide bearings are virgin (unreprocessed) PTFE resin, tested in accordance with the ASTM D1457 Standard and with reinforcing agents added. Such reinforcing agents include milled glass fibers. Type TF2 slide bearings exhibit the following average mechanical and physical properties:

Specific Gravity: 2.17 to 2.22
Tensile Strength: 2,200 psi
Elongation: 225%

Exact values for the mechanical and physical properties of each lot of Type TF2 are available upon request. Statements of certification for Epoxy and the TF2 Slide Bearings as well as MTR's for the steel components are available upon request.

◆ Type TFSS Slide Bearings

Type TFSS slide bearings are virgin (unreprocessed) PTFE resin, tested in accordance with the ASTM D1457 Standard and with reinforcing agents added. Such reinforcing agents include milled glass fibers. Type TFSS slide bearings exhibit the following average mechanical and physical properties:

Specific Gravity: 2.14 to 2.21
Tensile Strength: 3,500 psi
Elongation: 300%

Exact values for the mechanical and physical properties of each lot of Type TFSS are available upon request. Statements of certification for Epoxy and the TFSS Slide Bearings as well as MTR's for the steel components are available upon request.



TRI*SLIDE™ LOW FRICTION SLIDE BEARINGS

◆ Coefficient of Friction

The coefficient of friction shown in the charts in this document are the maximum values after the initiation of first movement. The coefficients of friction do not vary significantly with variations in temperature. As the speed of movement increases, the coefficients of friction will also increase. For a speed of movement of ten (10) inches per minute, the coefficients of friction will increase approximately forty-five (45) percent.

◆ Strength of Epoxy Bonding

The epoxy compound used has been specifically formulated for bonding Type TF2 and TFSS TRI*SLIDE™ slide bearings. It has been tested and proven to function as designed. The bonding strength between the PTFE element and the backing plate exceeds the required strength by 500 percent.

◆ Wear

When TRI*SLIDE™ slide bearings are utilized in typical thermal expansion applications in process and power plants, negligible wear is found to occur. In extreme climates where temperatures may reach -70 deg. F (-57 deg. C), TRI*SLIDE™ slide bearings have functioned as design with negligible wear, however impact loading should be avoided as PTFE becomes brittle at such low temperatures.

◆ Ultraviolet Testing

Testing Time accelerated tests have been conducted to determine the effects of ultraviolet rays on Type TF2 and TFSS slide bearings and no ill effects of any significance have been found. Once TRI*SLIDE™ slide bearings have been installed, the PTFE elements are protected from Ultraviolet rays for the most part by the steel backing plates as well as other near by steel and equipment in the process or power plants.

◆ Installation of TRI*SLIDE Slide Bearings

Type TF2 TRI*SLIDE™ slide bearings consists of two (2) PTFE bearings bonded to backing plates with a lip all the way around the PTFE bearings. With a 1/2" wide lip, the steel backing plate can be stitch welded or seal welded, as desired.

Where Type TF2 TRI*SLIDE™ slide bearings without a "Lip" are being installed, extreme care is to be taken to not exceed the 300 deg. F (149 deg C) limit during stitch welding. A maximum weld of 1" (25 mm) for every 6" (150 mm) of bearing edge is to be applied.

When excessive heat is applied to the steel, epoxy and PTFE during welding, the steel and the PTFE will separate. Whenever possible, Type TF2 TRI*SLIDE™ slide bearings without a "Lip" should be installed using mechanical attachments or bonding with an appropriate epoxy. Contact AAA Technology for such recommendations.

In all installations where the backing plate is welded to a structural member to attach the slide bearing, the bearing slide surface must be protected from weld splatter as well as all foreign matter that would scratch or gall the slide surfaces. While awaiting installation, the PTFE surfaces should be stored where they are not exposed for prolonged periods to the direct rays of the sun. All PTFE surfaces and Stainless Slide surfaces should have a protective covering until installation is completed.

Recommended Installation Procedure for a TRI*SLIDE™ Type TF2 Slide Bearing

A Typical TRI*SLIDE™ TF2 slide bearing will be supplied with a smaller bearing pad for use as the lower element and large bearing pad for use as the upper element.

1. The lower element should be installed first.
2. The PTFE bearing should be covered with a material that will protect it from weld splatter during installation.
3. Once the PTFE bearing is properly protected, the backing plate on the lower element should be stitch welded. If the bearing plate is to be seal welded, use the skip and fill technique. The temperature of the steel, epoxy and PTFE during welding is not to exceed 300 .deg. F (149 deg. C).
4. After the lower element has been installed, completely cover the PTFE on the upper slide bearing and the lower slide bearing.
5. Once the PTFE bearing is properly protected, the backing plate of the upper element should be stitch welded. If the backing plate is to be seal welded, use the skip and fill technique. The temperature of the steel, epoxy and PTFE during welding is not to exceed 300 deg. F (149 deg. C).
6. After welding or other installation methods are concluded the protective covering must be removed from the PTFE surfaces to allow for the desired movement to occur.

Recommended Installation Procedure for a TRI*SLIDE™ Type TFSS Slide Bearing

A Typical TRI*SLIDE™ TFSS slide bearing will be supplied with a smaller PTFE bearing pad for use as the lower element and a large Stainless Steel bearing pad for use as the upper element.

1. The lower element should be installed first .
2. The PTFE bearing should be covered with a material that will protect it from weld splatter during installation.
3. Once the PTFE bearing is properly protected, the backing plate on the lower element should be stitch welded. If the backing plate is to be seal welded, use the skip and fill technique. The temperature of the steel, epoxy and PTFE during welding is not to exceed 300 deg. F (149 deg. C).
4. After the lower element has been installed, completely cover the PTFE on the lower slide bearing and the Stainless Steel upper slide bearing.



TRI*SLIDE™ LOW FRICTION SLIDE BEARINGS

- Once the slide bearing surfaces are properly protected, the backing plate on the upper Stainless Steel slide bearing should be stitch welded. The backing plate may be seal welded, if desired.
- After welding or other installation methods are concluded, the protective covering must be removed from the PTFE surface and Stainless Steel slide bearing surface to allow for the desired movement to occur.

TRISLIDE™ G-S Slide Bearings for Service Temperatures - 300 deg F (149 deg C) to 750 deg F (399 deg C),

TRI*SLIDE™ G-S slide bearings are suitable for continuous use in the service temperature range defined in the section heading.

General Specifications

TRI*SLIDE™ G-S slide bearings are made of a stainless steel upper slide bearing bonded to a steel backing plate and a graphite G-S lower slide bearing constrained by a steel backing plate and frame. TRI*SLIDE™ G-S slide bearings are designed to reduce frictional resistance to movement at support or restraint points in piping systems and process equipment. When utilized properly, TRI*SLIDE™ G-S slide bearings will exhibit little if any wear during the expected life of the associated piping system.

Sizing for Loads and Movements

The lower slide bearing element should be sized for the load and the upper slide bearing element should be sized for the movement. To calculate the minimum bearing area of the lower G-S bearing pad in square inches, divide the load carried by the slide bearing element by the maximum load bearing rating in pounds per square inch for the TRI*SLIDE™ G-S. For a bearing temperature of 750° F (399 deg. C) and a load of 75,000 pounds, the required lower bearing area would be $75,000 \text{ lbs.} / 7,200 \text{ lbs./in}^2 = 10.42 \text{ in}^2$ (3" x 3.5" would equate to slightly more than the required area). The 7,200 lbs./in² compressive strength is with a 5 to 1 safety factor. Generally, customers design using about one half the maximum compressive strength which would mean that the graphite bearing requirement would be 21 in².

In addition to the dimensions of the TRI*SLIDE™ G-S bearing pad calculated above, 1 1/2" should be added to each of the four sides. In other words, if your lower bearing was determined to be 3 1/2" by 3", the outside of the steel frame containing the side bearing would be 6 1/2" by 6". The slide bearing backing plate can be any desired thickness with a minimum of 1/4" recommended and generally will be 1/2" wider and longer than the steel frame.

The lower slide bearing pad will be 1/2" thick TRI*SLIDE™ G-S. The minimum thickness of TRI*SLIDE™ G-S is 1/4", but the norm is 1/2" thick. Note also that as the temperature increases,

the load carrying capacity of the TRI*SLIDE™ G-S slide bearing does not decrease.

To properly size the upper slide bearing element, adhere to following procedure:

- Start with the required lower slide bearing area that you have determined to be necessary to carry the load. Do not use the dimensions of the steel frame.
- To the width required for load, add two times the lateral movement expected. Then add 1" or twenty (20) percent of the lateral movement, whichever is greater.
- To the length required for load, add two times the axial movement expected. Then add 1" or twenty (20) percent of the lateral movement, whichever is greater.
- For the upper slide bearing element, AAA Technology recommends a backing plate with a 1/2" lip on all sides. A large lip can be provided upon request. A smaller lip is not recommended since the slide plates are to be welded in place and a smaller lip may lead to separation of the TRI*SLIDE™ G-S from the backing plate upon installation.
- The upper slide bearing element is made of a 20 gauge Stainless Steel plate welded to a Carbon Steel backing plate. The backing plate may be as thin as 10 gauge, but you may specify any thickness you require.

Resistance to Movement

The coefficient of friction for the stainless steel slide bearing over the TRI*SLIDE™ G-S lower slide bearing is .1. In other words, when a vertical load of 10,000 pounds is carried on a TRI*SLIDE™ G-S Slide Bearing, a resistance force of 1,000 pounds must be overcome before movement occurs.

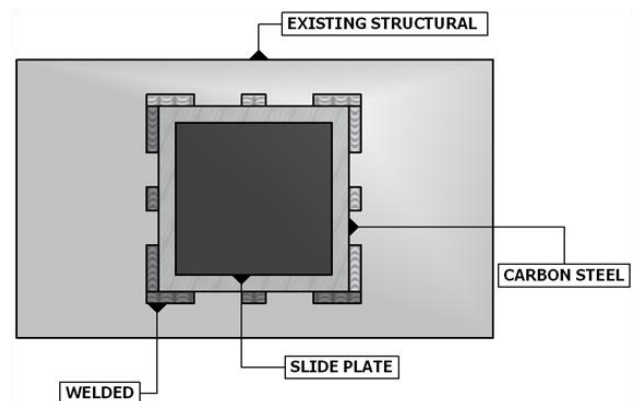



TRI*SLIDE™ LOW FRICTION SLIDE BEARINGS

Construction Options

Standard TRI*SLIDE™ G-S slide bearing assemblies are constructed of the following:

Type TRI*SLIDE™ G-S slide bearing options are as follows:

- ▲ Slide Bearing Thickness = as stated in above
- ▲ Backing Plate Thickness = Minimums as above
- ▲ Backing Plate Materials = Stainless Steel (SS), Carbon Steel without a finish (Black), Carbon Steel with Red Oxide Primer (Painted), Hot Dip Galvanized Carbon Steel (HDG)

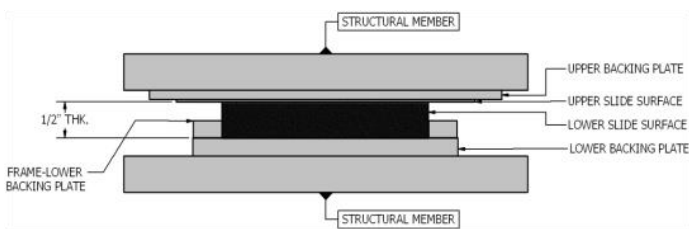

Additional Construction Options

- ▲ Holes - If required, holes for bolting the slide bearing to the structure may be specified by the customer. Bolt holes should not pass through the slide bearing surfaces.
- ▲ Studs or Anchors - If studs or anchors are to be welded to the backing plate, specify a backing plate thickness equal to at least the diameter of the stud or anchor.

Recommended Installation Procedure for a TRI*SLIDE™ G-S Slide Bearings -

A typical TRI*SLIDE™ G-S slide bearing will be supplied with a smaller graphite G-S bearing pad for use as the lower element and a larger Stainless Steel Bearing pad for use as the upper element.

1. The lower element should be installed first.
2. The TRI*SLIDE™ G-S bearing should be covered with a material that will protect it from weld splatter during installation.
3. Once the TRI*SLIDE™ G-S bearing is properly protected, the backing plate on the lower element should be stitch welded, use the skip and fill technique.
4. After the Lower element has been installed, completely cover the TRI*SLIDE™ G-S on the lower slide bearing and the Stainless Steel upper slide bearing.
5. Once the slide bearing surfaces are properly protected, the backing plate on the upper Stainless Steel slide bearing should be stitch welded to the structure. The Stainless Steel slide bearing may be seal welded, if desired.

6. After welding or other installation methods are concluded, the protective covering must be removed from the TRI*SLIDE™ G-S surface and the Stainless Steel slide bearing surface to allow for the desired movement to occur.

How to Specify TRI*SLIDE™ G-S Slide Bearings

Specify the following items to describe the TRI*SLIDE™ G-S slide bearings desired:

1. Customer Tag Number (Identifier)
2. TRI*SLIDE™ G-S
3. Define the Upper Element Properties
 - a. Slide Bearing Length, Width and Thickness
 - b. Backing Plate Length, Width and Thickness
 - c. Back Plate Material
4. Define the Lower Element Properties
 - a. Slide Bearing Length, Width and Thickness
 - b. Backing Plate Length, Width and Thickness
 - c. Backing Plate Material
5. Describe any Holes and/or Slots required. If any - tagged sketches should be attached to clarify hole and slot locations and sizes.
6. Describe any Studs and/or Anchor required. If any - tagged sketches should be attached to clarify stud and anchor locations and sizes.

For Example: # Tag # 1, TRI*SLIDE™ G-S

U, SS Slide Bearing 9", 6", .03", Backing Plate 10", 7", 10 Ga CS Black.

L, TRI*SLIDE™ G-S, 3", 2", .50" Backing Plate 6", 5", 0.25, CS Black.

TRI*SLIDE™ HT Slide Bearings for Service Temperatures - 300 deg F (149 deg C) to 1,200 deg. F (649 deg. C)

TRI*SLIDE™ HT slide bearings are suitable for continuous use in the service temperature range defined in the section heading.

General Specifications

TRI*SLIDE™ HT slide bearings are made of a stainless steel upper slide bearing bonded to a steel backing plate and a graphite HT lower slide bearing constrained by a steel backing plate and frame. TRI*SLIDE™ HT slide bearings are designed to reduce frictional resistance to movement at support or restraint points in piping systems and process equipment. When utilized properly, TRI*SLIDE™ HT slide bearings will exhibit little if any wear during the expected life of the associated piping system.

The compressive strength of TRI*SLIDE™ G-S is 7,200 psi and the compressive strength of TRI*SLIDE™ HT is 2,800 psi. The ability to handle the higher temperature is offset by the reduction in compressive strength. However, TRI*SLIDE™ HT will handle 1,200 deg. F (649 deg. C). The design procedures and the installation procedures for TRI*SLIDE™ HT are the same as those



TRI*SLIDE™ LOW FRICTION SLIDE BEARINGS

defined for TRI*SLIDE™ G-S with the one significant difference being that the compressive strength is less. Another consideration which must be taken into account is the need for the backing plates and frame members to be A-387-22 or stainless steel because of the elevated temperature.

TRI*SLIDE™ HIGH TEMP SLIDE BEARINGS - TYPE TSSM for Service Temperatures to 1,600 deg. F (871 deg. C)

General Specifications

TRI*SLIDE™ high temperature slide bearings are made of a stainless steel upper slide bearing bonded to a steel backing plate and a Meehanite® lower slide bearing constrained by a steel backing plate and frame. TRI*SLIDE™ high temperature slide bearings are designed to reduce frictional resistance to movement at support or restraint points in piping systems and process equipment. When utilized properly, TRI*SLIDE™ high temperature slide bearings will not show any significant wear during the expected life of the associated piping system.

Sizing for Loads and Movements

The lower slide bearing element should be sized for the load and the upper slide bearing element should be sized for the movement. To calculate the minimum bearing area of the lower high temperature bearing pad in square inches, divide the load carried by the slide bearing element by the maximum load bearing rating in pounds per square inch. For a bearing temperature of 1,200° F and a load of 55,000 pounds, the required lower bearing area would be $85,000\text{lbs} / 15,000\text{ lbs./in}^2 = 5.66\text{ in}^2$. Note also that as the temperature increases, the load carrying capacity of the slide bearing decreases.

Meehanite® is available in a variety of strengths and by contacting AAA Technology regarding your requirement, we can tailor the TSSM slide bearing to your specific requirements.

In addition to the dimensions of the high temperature bearing pad calculated above, 1 1/2" should be added to each of the four sides. In other words, if your lower bearing was determined to be 2" by 3", the outside of the steel frame containing the slide bearing would be 5" by 6". The slide bearing backing plate can be any desired thickness with a minimum of 1/4" recommended. The lower slide bearing pad will be 1/2" thick Meehanite®.

To properly size the upper slide bearing element, adhere to following procedure:

1. Start with the required lower slide bearing area that you have determined to be necessary to carry the load. Do not use the dimensions of the steel frame.
2. To the width required for load, add two times the lateral movement expected. Then add 1" or twenty (20) percent of the lateral movement, whichever is greater.

3. To the length required for load, add two times the axial movement expected. Then add 1" or twenty (20) percent of the lateral movement, whichever is greater.
4. For the upper slide bearing element, AAA Technology recommends a backing plate with a 1/2" lip on all sides. A large lip can be provided upon request. A smaller lip is not recommended since the SS slide bearing weld could be damaged during the welding of the backing plate to the structure.
5. The upper slide bearing element is made of a 20 gauge Stainless Steel plate welded to a Carbon Steel backing plate. The backing plate may be as thin as 10 gauge, but you may specify any thickness you require.

Construction Options

Standard TRI*SLIDE™ high temp slide bearing assemblies are constructed of the following:

Resistance to Movement The coefficient of friction for the stainless steel slide bearing over the Meehanite® lower slide bearing is .15. In other words, when a vertical load of 10,000 pounds is carried on a TRI*SLIDE High Temp Slide Bearing, a resistance force of 1,500 pounds must be overcome before movement occurs.

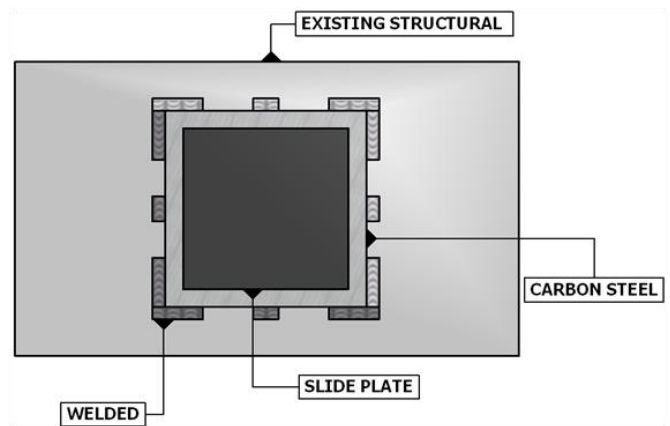

Type TSSM TRI*SLIDE high temp slide bearing options are as follows:

- ▲ Slide Bearing Thickness = as stated in table above
- ▲ Backing Plate Thickness = Minimums as above
- ▲ Backing Plate Materials = Stainless Steel (SS), Carbon Steel without a finish (Black), Carbon Steel with Red Oxide Primer (Painted), Hot Dip Galvanized Carbon Steel (HDG)



TRI*SLIDE™ LOW FRICTION SLIDE BEARINGS

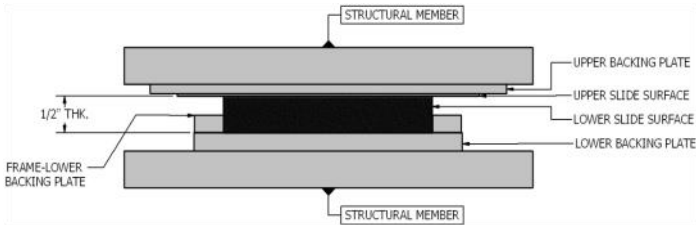

Additional Construction Options

▲ Holes - If required, holes for bolting the slide bearing to the structure may be specified by the customer. Bolt holes should not pass through the slide bearing surfaces.

▲ Studs or Anchors - If studs or anchors are to be welded to the backing plate, specify a backing plate thickness equal to at least the diameter of the stud or anchor.

Recommended Installation Procedure for a TRI*SLIDE™ Type TSSM High Temp Slide Bearings -

A typical TRI*SLIDE™ TSSM slide bearing will be supplied with a smaller Meehanite® bearing pad for use as the lower element and a larger Stainless Steel Bearing pad for use as the upper element.

1. The lower element should be installed first.
2. The Meehanite® bearing should be covered with a material that will protect it from weld splatter during installation.
3. Once the Meehanite® bearing is properly protected, the backing plate on the lower element should be stitch welded, use the skip and fill technique.
4. After the Lower element has been installed, completely cover the Meehanite® on the lower slide bearing and the Stainless Steel upper slide bearing.
5. Once the slide bearing surfaces are properly protected, the backing plate on the upper Stainless Steel slide bearing should be stitch welded to the structure. The Stainless Steel slide bearing may be seal welded, if desired.
6. After welding or other installation methods are concluded, the protective covering must be removed from the Meehanite® surface and the Stainless Steel slide bearing surface to allow for the desired movement to occur.

How to Specify Type TSSM TRI*SLIDE™ High Temp

Slide Bearings Specify the following items to describe the slide bearings desired:

1. Customer Tag Number (Identifier)
2. Type "TSSM"
3. Define the Upper Element Properties
 - a. Slide Bearing Length, Width and Thickness
 - b. Backing Plate Length, Width and Thickness
 - c. Back Plate Material
4. Define the Lower Element Properties
 - a. Slide Bearing Length, Width and Thickness
 - b. Backing Plate Length, Width and Thickness
 - c. Backing Plate Material
5. Describe any Holes and or Slots required, If any- Tagged sketches should be attached to clarify hole and slot locations and sizes.
6. Describe any Studs and or Anchor required, If any tagged sketches should be attached to clarify stud and anchor locations and sizes.

For Example: # Tag # 1, Type TSSM

U, SS Slide Bearing 9", 6", .03", Backing Plate 10", 7", 10 Ga CS Black.

L, M Slide Bearing 3", 2", .50" Backing Plate 6", 5", 0.25, CS Black.

Other Quality Products Available from AAA Technology



Fig. 5120-WP



Fig. 5110-WP-TB



Fig. 51201-TC



TRI-STAND OPTIONS





AAA TECHNOLOGY & SPECIALTIES CO., INC.



6219 Brittmoore Road • Houston, Texas 77041-5114, U.S.A.
Telephone: 713-849-3366 • FAX: 713-849-3654
E-mail: info@aaatech.com • Website: http://www.aaatech.com

PIPE HANGERS, SUPPORTS, RESTRAINTS & FABRICATION



EQUAL™ HI-LOAD BOX SPRINGS

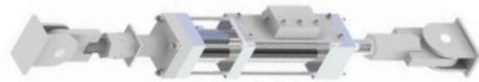

EQUAL™ HYDRAULIC SNUBBER ASSEMBLIES



EQUAL™ RIGID SWAY STRUT ASSEMBLIES

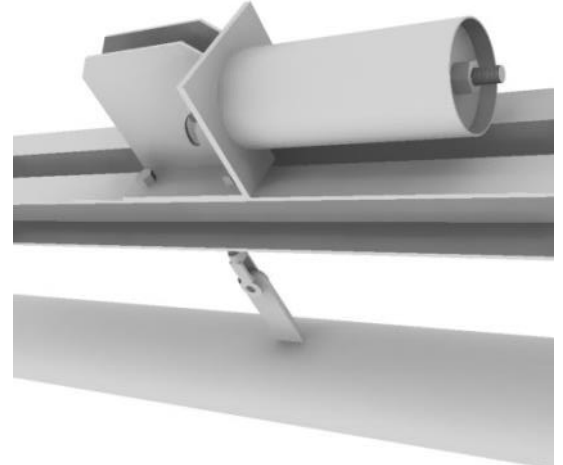

EQUAL™ ENGINEERED CONSTANT SPRING HANGERS



EQUAL™ LIMIT STOPS



EQUAL™ DAMPERS & SWAY BRACES



EQUAL™ LARGE DIA. ROLLERS



THREADED HANGER RODS



ADJUSTABLE PIPE STANDS



VIBRATION CONTROL HOLD DOWN CLAMPS



TRI*FOAM & TRI*CAL INSULATED SUPPORTS



PIPE SHOES, GUIDES & LINE STOPS



TRI-SLIDE™ LOW FRICTION BEARINGS



HANGER HARDWARE & AN EXTENSIVE INVENTORY OF HANGER COMPONENTS



FABRICATED TO YOUR SPECIFICATION



CORROSION RESISTANT

EQUAL™ ENGINEERED VARIABLE SPRING HANGERS

Associated Services Offered

- **Piping Stress Analysis Services** - Need to know what pipe supports to select or why the loads on your equipment or the stresses in your piping system are too high? We can perform a TRIFLEX® piping stress analysis and tell you and we can recommend solutions.
- **Pipe Hanger Fitness for Service Studies** - Need to sort out whether the pipe supports and spring hangers in your plant are performing as originally intended or if corrosion has affected their ability to perform? We can help make these determinations and provide you with complete documentation as well as offer recommendations for improvements.